

2024 INTEGRATED REPORT

SK SIGDO KOPPERS S.A.





Dear shareholders,

I present below our summary Integrated Report that explains the financial and sustainability results of Sigdo Koppers.

There were signs of stabilization of the world economy during 2024. However, the different geopolitical conflicts around the world and threats of changes to tariffs in some countries kept international markets under a degree of uncertainty while they were facing trade difficulties that were affecting projections.

Chile grew 2.6% in 2024, reflecting the challenges faced by the country because of the standstill in productivity, a lack of investment, an inflation that is not yet entirely under control even though it is gradually falling, and a high level of government debt. In view of these conditions, added to external factors, it is not only fundamental that permit barriers be reduced, which are braking investment, but also that signs of governability be given to afford our country the necessary stability. Only in that way will we be able to resume the path toward development and provide long-term solutions to people's needs. Yet there are signs that make us optimistic about the future, especially in the mining sector, the focus of the business strategy of Sigdo Koppers and its subsidiaries. According to reports by the Chilean Copper Association (Cochilco), mining investments are estimated to total around US\$85 billion in the coming years, and 90% of that amount will be allocated to copper mining projects.

In this scenario, our strategy of being a global supplier of services and products to mining and industry has enabled us to address the challenges in the environment.

We are present in the markets most important to our businesses, and today we are strategic partners of customers around the world with whom we are developing integral solutions based on permanent innovation. This means that we provide added value to our supply, that our businesses are in a competitive position and are financially sound. At the close of 2024, income totaled US\$3.781 billion, and approximately 60% of that came from operations outside of Chile, which reveals the success of the internationalization strategy we have been implementing since 2012. The net profit in the period was US\$103 million. In particular, we reached the self-imposed goal of reducing working capital and net finance expenses. The consolidated EBITDA totaled US\$535 million.

As of December 31, 2024, the Consolidated Assets of Sigdo Koppers totaled US\$4.763 billion, in line with the close of 2023, and it held consolidated cash of US\$556 million, an increase of 30%.

Like in recent years, our subsidiaries have faced challenges in their industries that they have addressed from a long-term standpoint according to our defined strategy. They also made significant progress in regional or global diversification. In terms of innovation, they have added products and services committed to sustainability that have been recognized by our customers and the market, and they were awarded new contracts and brands to represent, which allows us to forecast a positive future.

At the end of November, in line with Sigdo Koppers' purpose of focusing its businesses, investments and development on the mining and industry sectors, we concluded the sale of our interest in Astara Latam S.A., an automobile dealership. The transaction was also consistent with the group's decision to hold a majority ownership interest in the companies in which it is a shareholder.

In 2024, through Fundación Chile Dual, we redoubled our efforts to effectively link the production sector to vocational high schools. We helped close to 7,000 students, 359 teachers and 139 schools (15% of all schools in the nation) through different initiatives. We have developed diverse programs with all of them to be able to effectively fulfill our commitment to support youths in developing their abilities and to further social progress.

For the tenth consecutive year, Sigdo Koppers is a member of the Dow Jones Sustainability Index that highlights the companies with the best sustainability performance. At the same time, we are holding true to our commitment to aid in the development of the countries where we are present through our participation in the U.N. Global Compact. These efforts are in line with Sigdo Koppers' sustainability strategy, which has been reinforced in recent years by increasingly more robust social and environmental indicators.

In 2025, SK Ingeniería y Construcción, the company that was the start of the Sigdo Koppers group, turned 65. In those 65 years, we have held strong to the permanent commitment to the development of the industry and of people in Chile. Despite the complexities we envisage, we can, because of our extensive history, project a significant growth, so we will continue to be concentrated on making investments under the internationalization plan, which have helped us strengthen our global competitiveness, and on continuing to focus on mining and industry.

JUAN EDUARDO ERRÁZURIZ OSSA

Executive Chairman
Sigdo Koppers S.A.

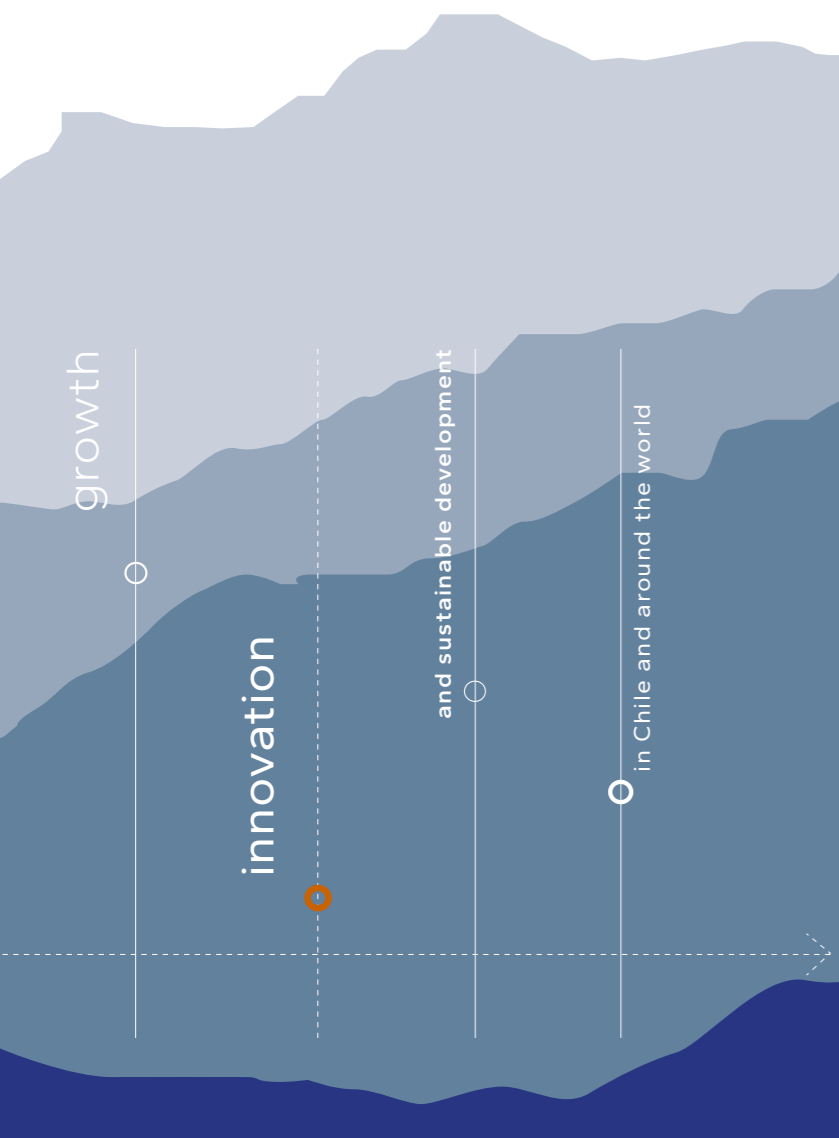

OUR COMPANY

OUR ACTIVITIES

THE COMPANY IS ENGAGED IN THE MAIN ACTIVITIES THAT CREATE VALUE FOR CUSTOMERS BY PROVIDING HIGHLY COMPLEX, INTEGRAL SOLUTIONS IN THE PRINCIPAL STAGES IN THE CHAIN OF MINING AND INDUSTRY.

SUSTAINABILITY REPORTING
BOUNDARIES: ALL ACTIVITIES UNDER OPERATIONAL CONTROL AND/OR MAJORITY-OWNED ARE COVERED

Mining and industry value chain

Development

Development of the leading industrial investment projects



INGENIERÍA Y CONSTRUCCIÓN SIGDO KOPPERS GROUP S.A. (SKIC GROUP)

The SKIC Group provides large-scale engineering, construction and assembly services in the mining, power generation and transmission sectors, to industrial projects, and builds civil and maritime works and infrastructure.

01.

Operation

Solutions in the main stages of industrial and mining operations



ENAEX S.A.

Enaex is the leading producer of explosive-grade ammonium nitrate in the region and a leader in rock fragmentation services and in the development and sale of explosives with a high added value.

02.



SKC S.A.

SKC imports, distributes and leases machinery to companies engaged in mining, agriculture, transportation and industry.

03.

Process

Solutions in the material processing stages



MAGOTTEAUX GROUP S.A.

The Magotteaux Group produces and sells wear parts (castings) and grinding balls with a high added value, used in large-scale mining and in industries like the cement industry, by thermal power plants and in dredging, to name a few.



SK GODELIUS S.A.

SK Godelius develops technologies that optimize customers' operating processes. It creates, implants and operates telecommand systems, the automation of machinery and production processes, among other solutions.

04.

Logistics

Cargo logistics and transfer solutions



PUERTO VENTANAS S.A. (PVSA)

PVSA is the leading bulk port in the central zone of Chile. It provides transfer and storage services. The company also operates Puerto Andino, located in the north of Chile.



FERROCARRIL DEL PACÍFICO S.A. (FEPASA)

Fepasa provides cargo logistics and transfer services by rail and by truck.



GLOBAL PRESENCE

Sigdo Koppers S.A. has direct production plants and operations on the five continents, in addition to selling its products and services globally.

The company is implementing a market diversification strategy under which the goal is to be present in the regions and countries with a greater mining and industrial development in order to provide a timely, quality supply to its customers.

EE.UU.
Enaex
Magotteaux Group

CANADA
Magotteaux Group
SK Godelius

MEXICO
Magotteaux Group

COLOMBIA
SKC

BRAZIL
Enaex
Magotteaux Group
SKIC Group

CHILE
Enaex
Magotteaux Group
PVSA
Fepasa
SKIC Group
SK Godelius
SKC

ARGENTINA
Enaex

PERU
Enaex
SKIC Group
SKC

SPAIN
Magotteaux Group

FRANCE
Enaex
Magotteaux Group

BELGIUM
Magotteaux Group

SOUTH AFRICA
Enaex
Magotteaux Group

AUSTRALIA
Enaex

THAILAND
Magotteaux Group

CHINA
Magotteaux Group

INDIA
Magotteaux Group



16

DIRECT OPERATIONS IN 16 COUNTRIES AND COMMERCIAL OFFICES IN MORE THAN 30
CONSOLIDATE THE GLOBAL PRESENCE OF SIGDO KOPPERS.

CONSOLIDATED SALES BY REGION

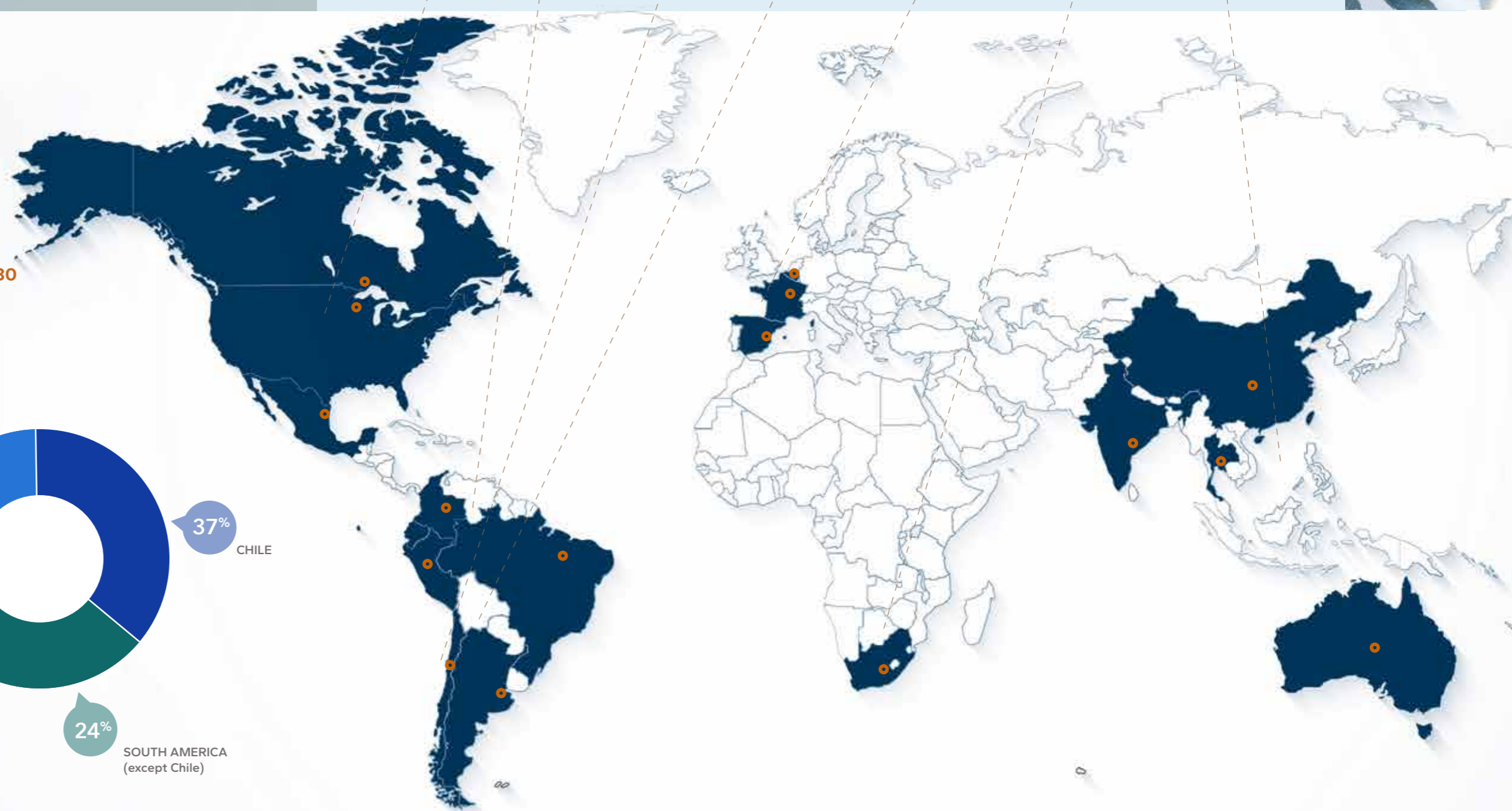
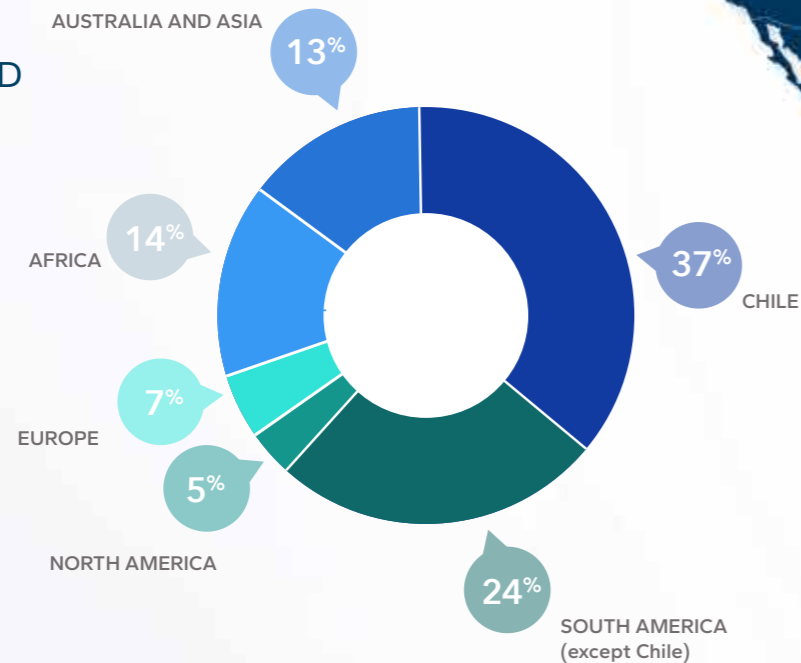

MISSION, VISION, PURPOSE AND VALUES

Mission

Be an integral supply group and leader in services and products to mining and industry. Provide the highest quality to our customers, create value for our shareholders, and opportunities for our employees to develop.

Vision

Grow profitably, continuously and sustainably. Consolidate our development in the different industries and markets in which we engage and identify new opportunities for investment in harmony with our long-term vision.

values

Purpose

Contribute to the growth of the countries where we are present, to social progress and to the development of the industry.



Commitment to Life

We prioritize the health, safety and quality of life of people. We aim to grow sustainably while caring for the environment and assuring the wellbeing of related communities.

Integrity

We behave ethically, fairly and responsibly toward our stakeholders.

Customer Focus

We build long-term relationships of trust. We endeavor to understand their needs, look at them from their point of view, and meet their expectations by means of competitive, quality solutions.

Excellence

We provide quality products and services. We endeavor to innovate and find the best solutions.

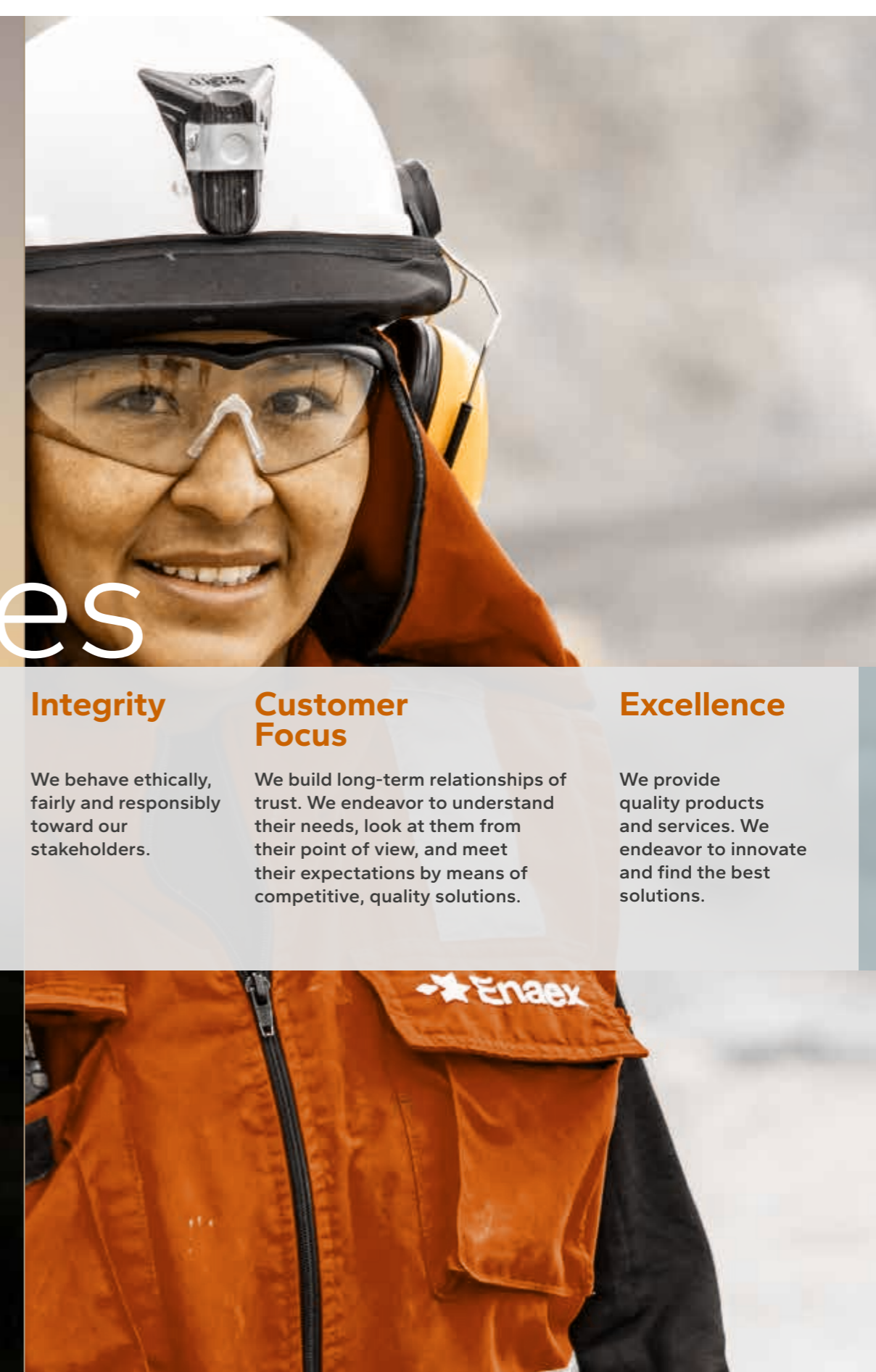

CORPORATE GOVERNANCE

THE CORPORATE GOVERNANCE STRUCTURE AND MANAGEMENT OF SIGDO KOPPERS S.A. AIM TO INCREASE THE COMPANY'S VALUE SUSTAINABLY BY ACHIEVING ITS GOALS, ALWAYS ALIGNED WITH THE ORGANIZATION'S VALUES AND PRINCIPLES.

THIS MODEL PROVIDES A FRAMEWORK OF ACTION UNDER WHICH OFFICERS ENDEAVOR TO MAXIMIZE THE COMPANY'S RESULTS ACCORDING TO THE DIRECTIVES OF THE BOARD, ON BEHALF OF THE SHAREHOLDERS, AND IN CONSIDERATION OF THE INTERESTS OF ALL STAKEHOLDERS.

Sigdo Koppers upholds strong governance standards and ensures board accountability through the following measures:

- Board members maintain an average attendance rate above 75% at meetings
- Any changes to the company bylaws require shareholder approval
- The company's board of directors is composed of 9 members, 6 of whom have at least 1 additional mandate in publicly listed companies
- A CEO succession plan is in place to ensure leadership continuity
- Regular board performance evaluations are conducted to promote continuous improvement
- There are no limitations on directors' liabilities, reinforcing their responsibility and commitment

% OWNERSHIP INTERESTS IN 2024

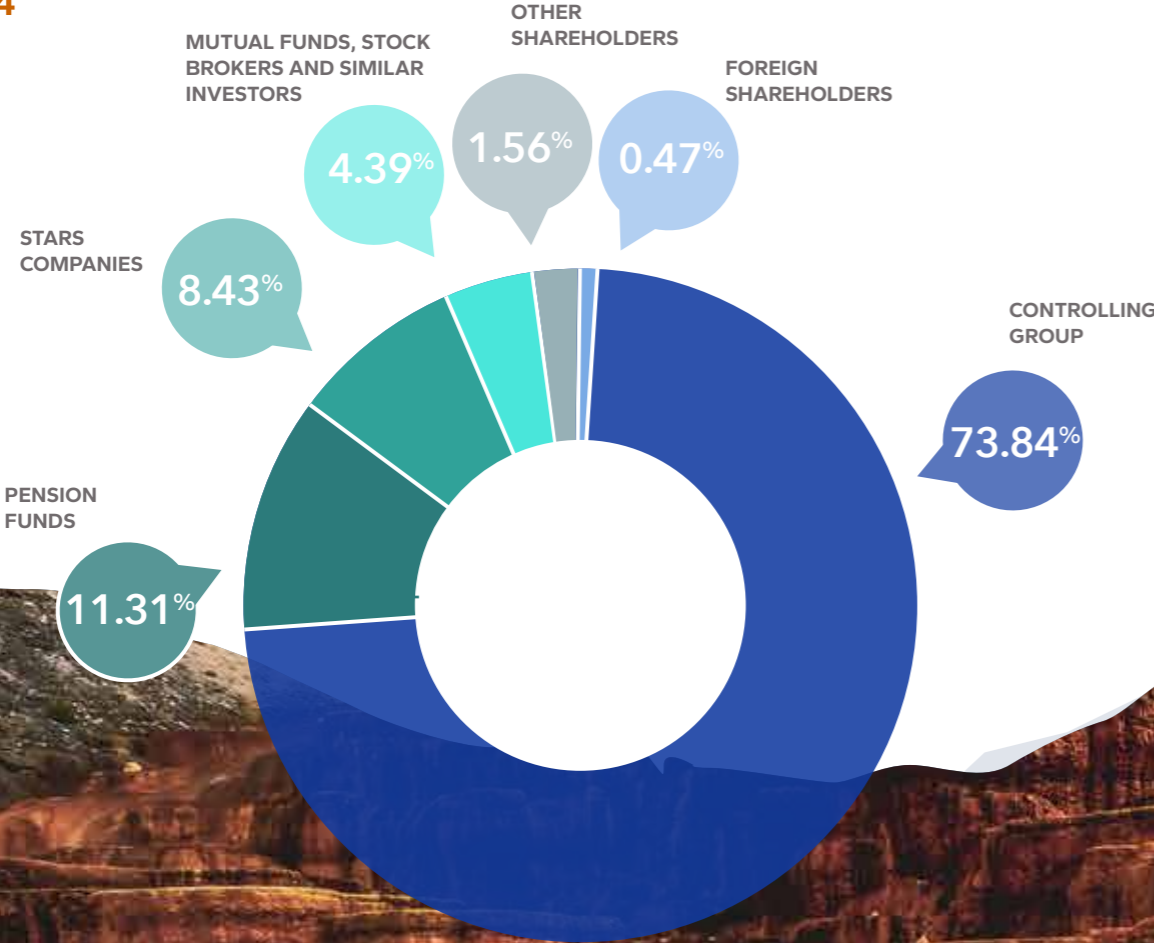

CORPORATE STRUCTURE

• 60.7%	Enaex S.A	
• 100.0%	Magotteaux Group S.A.	
• 50.0%	Puerto Ventanas S.A.	• 51.8%
• 94.4%	Ingeniería y Construcción Sigdo Koppers Group S.A.	
• 78.5%	SK Godelius S.A.	
• 87.9%	SKC S.A.	

Sigdo Koppers S.A

Ferrocarril del Pacífico S.A.

3.8

years

average tenure
of board members

Board of Directors

The actual Board was elected for the period 2024-2027 at the Extraordinary Shareholders Meeting held April 29, 2024

The efficiency of Board meetings is analyzed during the annual self-evaluation process.



JUAN EDUARDO ERRÁZURIZ OSSA

Executive Chairman

Tax I.D. 4.108.103-1
Ingeniero Civil



SILVIO ROSTANGO HAYES

Vice-Chairman

Tax I.D. 6.366.718-8
Ingeniero Civil



MARÍA VERÓNICA MORALES MENA

Independent Director (*)

Tax I.D. 6.980.834-4
Ingeniero Comercial



MARCOS BUCHI BUC

Director (*)

Tax I.D. 7.383.017-6
Ingeniero Civil



GONZALO PAVEZ ARO

Director

Tax I.D. 9.417.024-9
Ingeniero Comercial



VICTORIA VÁSQUEZ GARCÍA

Directora

Tax I.D. 6.458.603-3
Ingeniero Comercial



NAOSHI MATSUMOTO COURDURIER

Director

Tax I.D. 9.496.299-4
Ingeniero Comercial



PATRICIO LEIGHTON ZABELLI

Director

Tax I.D. 8.255.566-8
Ingeniero Comercial



LUIS FELIPE CERÓN CERÓN

Director (*)

Tax I.D. 6.375.799-3
Ingeniero Civil

*Members of the Directors Committee. The company has no alternate directors.

COMPOSITION AND TENURE OF THE BOARD OF DIRECTORS

Matrix of Board knowledge, skills and experience

WOMEN MEN

	WOMEN	MEN
Number of directors by sex and nationality		
Chilean	2	7
Number of directors by age range		
From age 51 to 60	0	2
From age 61 to 70	1	4
Older than 70	1	1
Total	2	7
Number of directors by time in office		
Less than 3 years	2	4
From 3 to 6 years	0	0
More than 6 and less than 9 years	0	2
From 9 to 12 years	0	0
More than 12 years	0	1
Total	2	7
Number of directors with disabilities	0	0

Juan Eduardo Errázuriz Ossa
Executive Chairman

He earned a degree in civil engineering from the Catholic University of Chile. He is a shareholder in Sigdo Koppers S.A. and Chairman of the boards of Enaex S.A. and Puerto Ventanas S.A., among others. He is a Councilmember of the Manufacturing Development Society of Chile (abbreviated as SOFOFA in Spanish). Over the course of his career, he has been a member of the boards of IBM International, Lan Airlines and Endesa Chile, and he has been honored by the governments of Japan, Argentina, Peru and Belgium.

Silvio Rostagno Hayes
Vice-Chairman

He holds a degree in civil engineering from the Catholic University of Chile and a M.Sc. from Stanford University in California, U.S.A. He is a director in many companies: since 2018 in Sigdo Koppers, Pucobre, Cial Alimentos, Ventisqueros (Salmon) and Viña Odfjell, among others. He was formerly a director in Drake Enterprises, CEO of D&S Retail and Walmart Retail, CEO of Viña Santa Rita, Commercial Vice-President of the Chilesat Group, Gilat Satellite Networks, a partner in Heidrick & Struggles, CEO of Lotus Development Corp for Chile and South America.

Luis Felipe Cerón Cerón
Director

He holds a degree in industrial engineering, specializing in electricity, from the Catholic University of Chile and a Master of Science in Accounting and Finance from the London School of Economics. He was Chief Project Engineer of the National Energy Commission, Assistant Finance Manager of Bancard, Chief Development Officer at SQM and CEO of Electrica Guacolda, Central Puerto de Buenos Aires, SCL Terminal Aereo Santiago and AES Gener S.A. He was also Executive Chairman of AES Gener S.A. and Executive Director of Energia Llaima. He was a member of the board of AES Chivor in Colombia, AES Tiete and AES Electropaulo in Brazil. He is a director in Moly met and Euroamerica, among others.

Victoria Vásquez García
Director

She holds a degree in business engineering from the Catholic University of Chile and studied at the Kellogg School at Northwestern University and at University of the Andes. She is President of NorQuim SpA and a Director of Cencosud Shopping, Puerto Ventanas, SURA Property/Casualty and Life Insurance, IST and Fundación Chile Dual, among others. In the past, she has been a member of the board of CCR, CMP, Amcham, Campport and INACAP. She was also Vice-Chairman of Empresa Portuaria San Antonio and of the Manufacturing Development Society of Chile (abbreviated as SOFOFA in Spanish).

María Verónica Morales Mena
Director

She holds a business engineering degree from the Catholic University of Chile. She has been a director of Camanchaca, Watts, Socovesa, Empresa de Ferrocarriles del Estado (Chile), Hortifrut and San Francisco Educational Foundation, among others. She was also Chief Research Officer of IANSA and of the National Society of Agriculture of Chile.

Marcos Büchi Buc
Director

He has a degree in structural engineering from the University of Chile and is an Executive Director and Advisor to Santo Tomas University in Chile. He is chairman of Cementos Polpaico and a director of Almendral and Endeavor. He was previously a member of the boards of Consorcio Financiero, Consorcio Seguros Vida, CN Life Seguros Vida, Consorcio Seguros Generales, AELA Energia, Codelco, Empresa Electrica Guacolda, Empresas Sanitarias Aguas Nuevas, Aguas del Altiplano, Aguas Araucania, Aguas Magallanes, Cruz Blanca and Empresa de Ferrocarriles del Estado (Chile). He was also chairman of Sociedad Minera Invierno, Noracid and Asociación de Aseguradores de Chile A.G., vice-chairman of Esval, and CEO of Ultraterra, Chilquinta Energia and Consorcio Nacional de Seguros Vida.

Patricio Leighton Zambelli
Director

He holds a business engineering degree from the University of Chile and an MBA from the Kellogg School of Management at Northwestern University. He is the CEO of Stars Companies and a Director in Enaex, Clinica Meds, Kayyak Ventures and Z Hotels, among others. He was the manager of the CorpCapital Division, President of CorpCapital Corredores de Bolsa, President of CorpCapital Asesorias Financieras, Director of CorpCapital Administradora General de Fondos S.A., Chief Capital Markets Officer of BICE Chileconsult Asesorias Financieras, and Associate of the Corporate Finance Group of N M Rothschild & Sons, an Associate of the Corporate Finance Group of Chase Securities, Inc. for Latin America, and a professor of Finance in the MBA program of the Catholic University of Chile.

Gonzalo Pavez Aro
Director

He has a business engineering degree from Gabriela Mistral University. He is the Executive Director of Mariagri, an agricultural company, President of DEVISA, a property management company, and Director of Grupo Security, Vida Security and Factoring Security. In the past, he has been a member of the board of SKC Maquinarias S.A. and SKC Maquinarias Peru, among others.

Naoshi Matsumoto Courdurier
Director

He holds a business engineering degree from Gabriela Mistral University and a Dual MBA from the School of Management of Adolfo Ibañez University and Deusto Business School. He is CEO of Inversiones Matycol, President of PC Factory S.A. and the Ganbaru Foundation, and a Director of Grupo Security, SKC, SK Rental, Travel Security, Godelius, and Fundación Chile Dual. In the past, he has been a member of the boards of directors of Enaex, Modyo, Ferrocarril del Pacífico, Somela, Valores Security and Chile's Olympic Committee. He was also Vice-President of Corporate Development at SKBergé and Fiat CEO for Comercial Itala S.A., among other positions.

Main Shareholders of Sigdo Koppers S.A.

Name (surname, mother's maiden name, names)	Number of shares subscribed in 2024	% ownership in 2024	% ownership in 2023
SOCIEDAD DE AHORRO KAIZEN SPA	100,160,000	9.32%	9.32%
SOCIEDAD DE AHORRO JUTLANDIA SPA	100,160,000	9.32%	9.32%
SOCIEDAD DE AHORRO CERRO DIECIOCHO LIMITADA	100,160,000	9.32%	9.32%
SOCIEDAD DE AHORRO HOMAR SPA	100,160,000	9.32%	9.32%
INVERSIONES BUSTURIA SPA	91,225,402	8.49%	8.49%
BTG PACTUAL CHILE S.A. CORREDORES DE BOLSA	55,251,283	5.14%	4.47%
MALAGA ASESORIAS Y CONSULTORIAS SPA.	33,361,009	3.10%	3.10%
ITAU CORREDORES DE BOLSA LTDA.	31,917,861	2.97%	3.00%
PIONERO FONDO DE INVERSION MOBILIARIO	21,949,944	2.04%	2.50%
INVERSIONES KAIZEN DOS SPA.	19,350,000	1.80%	1.80%
INVERSIONES CERRO DIECIOCHO DOS SPA.	19,350,000	1.80%	1.80%
INVERSIONES HOMAR DOS SPA.	19,350,000	1.80%	1.80%
INVERSIONES JUTLANDIA DOS SPA.	19,350,000	1.80%	1.80%
INVERSIONES BUSTURIA DOS SPA.	19,350,000	1.80%	1.80%
FONDO DE PENSIONES HABITAT C	15,299,339	1.77%	1.50%
Total	746,394,838	69.77%	69.33%

Family Ownership

Currently, the company has a controlling group. The percentage controlled, both directly and indirectly, by the controller of each of its members is as follows:

Controllers	Number of Shares held directly	Direct Ownership	End Controller	Number of Shares held indirectly and by Related Parties	% Indirect and Related-Party Ownership	Total Number of Shares	Ownership Total
Villarrica Uno SpA ⁽¹⁾	14,992,406	1.39%	Juan Eduardo Errázuriz Ossa	8,432,895	0,78%	126,747,794	11,79%
Villarrica Dos SpA ⁽¹⁾	14,992,406	1.39%	Juan Eduardo Errázuriz Ossa				
Villarrica Tres SpA ⁽¹⁾	14,992,406	1.39%	Juan Eduardo Errázuriz Ossa				
Villarrica Cuatro SpA ⁽¹⁾	14,992,406	1.39%	Juan Eduardo Errázuriz Ossa				
Villarrica Cinco SpA ⁽¹⁾	14,992,406	1.39%	Juan Eduardo Errázuriz Ossa				
Villarrica Seis SpA ⁽¹⁾	14,992,406	1.39%	Juan Eduardo Errázuriz Ossa				
Villarrica Siete SpA ⁽¹⁾	14,992,406	1.39%	Juan Eduardo Errázuriz Ossa				
Villarrica Ocho SpA ⁽¹⁾	13,368,057	1.24%	Juan Eduardo Errázuriz Ossa				
Sociedad de Ahorro Kaizen SpA ⁽²⁾	100,60,000	9.32%	Naoshi Matsumoto Takahashi	5,478,338	0,51%	124,988,338	11,63%
Inversiones Kaizen Dos SpA ⁽²⁾	19,350,000	1.80%	Naoshi Matsumoto Takahashi				
Sociedad de Ahorro Jutlandia SpA ⁽³⁾	100,160,000	9.32%	Norman Hansen Roses	2,946,431	0,27%	122,456,431	11,39%
Inversiones Jutlandia Dos SpA ⁽³⁾	19,350,000	1.80%	Norman Hansen Roses				
Sociedad de Ahorro Homar SpA ⁽⁴⁾	100,160,000	9.32%	Horacio Pavez García	16,983,412	1,58%	136,493,412	12,70%
Inversiones Homar Dos SpA ⁽⁴⁾	19,350,000	1.80%	Horacio Pavez García				
Sociedad de Ahorro Cerro Dieciocho Limitada ⁽⁵⁾	100,160,000	9.32%	Familia Santander García	10,050,000	0,93%	129,560,000	12,05%
Inversiones Cerro Dieciocho Dos SpA ⁽⁵⁾	19,350,000	1.80%	Familia Santander García				
Inversiones Busturia SpA ⁽⁶⁾	91,225,402	8.49%	Familia Aboitiz Domínguez	9,643,132	0,90%	120,218,534	11,8%
Inversiones Busturia Dos SpA ⁽⁶⁾	19,350,000	1.80%	Familia Aboitiz Domínguez				
Málaga Asesorías y Consultorías SpA	33,361,009	3.10%	Socios Málaga, Asesorías y Consultorías Spa	0	0,00%	33,361,009	3,10%
Total	740,291,310	68.86%		53,534,208	4.98%	793,825,518	73,84%

MULTIPLE OF BASE SALARY

Executive President:

362x

Senior executives:

57x

Management of Sigdo Koppers S.A.

JUAN EDUARDO ERRÁZURIZ OSSA



Executive Chairman

Tax I.D. 4.108.103-1
Civil Engineer

Appointed April 30, 2010

JUAN PABLO ABOITIZ DOMÍNGUEZ



Chief Executive Officer

Tax I.D. 7.510.347-6
Civil Engineer

Appointed April 30, 2007

ANDRÉS BRINCK LABBÉ



Chief Finance Officer

Tax I.D. 9.975.260-2
Business Engineer

Appointed April 1, 2024

ALEJANDRO REYES PIZARRO



Comptroller

Tax I.D. 8.386.498-2
Business Engineer

Appointed May 1, 2003

ESG and Sustainability Governance

Sigdo Koppers has established a formal governance structure to ensure effective oversight of ESG and sustainability matters across all levels of the organization:

- The Board of Directors holds ultimate responsibility for overseeing ESG and sustainability issues
- An executive-level ESG/Sustainability Committee has been established to lead and coordinate strategic initiatives in this area
- A dedicated role has been appointed to manage and monitor ESG and sustainability performance on an ongoing basis

MATERIALITY ANALYSIS AT SIGDO KOPPERS

Sigdo Koppers conducts a comprehensive materiality analysis to ensure its sustainability efforts remain aligned with stakeholder expectations and business priorities.

The process includes the following key elements:

01. Integration with Risk Management:

The materiality assessment is integrated into the company's Enterprise Risk Management (ERM) process

02. Double Materiality Perspective:

The analysis considers both the impact of ESG issues on the company and the company's impact on society and the environment

03. Stakeholder Engagement:

External stakeholders are actively involved in identifying the most relevant ESG issues

04. Prioritization:

Material topics are prioritized using a materiality matrix or a similar structured approach

05. Governance:

The final results of the materiality assessment are reviewed and approved by Senior Management.

RISK MANAGEMENT

Sigdo Koppers has a corporate Risk Management Policy that aims to provide a reasonable level of certainty in achieving strategic, operating, financial and regulatory goals while contributing to the creation of value for the company.

The Policy discusses the main risk guidelines that set down the directives, roles and responsibilities of the individuals and bodies in charge of the risk process. The Risk Management Procedure defines a structured framework for the identification, analysis, assessment, monitoring and communication of risks to the pertinent individuals.

Risks are managed and administrated by means of a process aligned with the rules and regulations governing in Chile and in the countries where the company operates. International standards and the best industry practices in the world have been adopted.

The Company is currently working under the following standards and practices:

- **COSO**
(Committee of Sponsoring Organizations of the Treadway Commission)
- **COBIT**
(Control Objectives for Information and Related Technology)
- **ISO**
(International Organization for Standardization)

The foregoing notwithstanding, the company is continually adding indicators aligned to the best industry practices, thereby strengthening its focus on sustainability and the management of emerging risks.

Risk analysis, essential in a setting of ongoing change, is made globally, regionally and locally to evaluate threats, design mitigation strategies and create monitoring plans to control and track risks.

THE COMPANY IS CONTINUALLY TRAINING EMPLOYEES
IN THE MANAGEMENT OF RISKS.

○ **172**
critical risks were identified in the group

○ **100%**
of subsidiaries were assessed for risks and action plans were designed for high-level risks

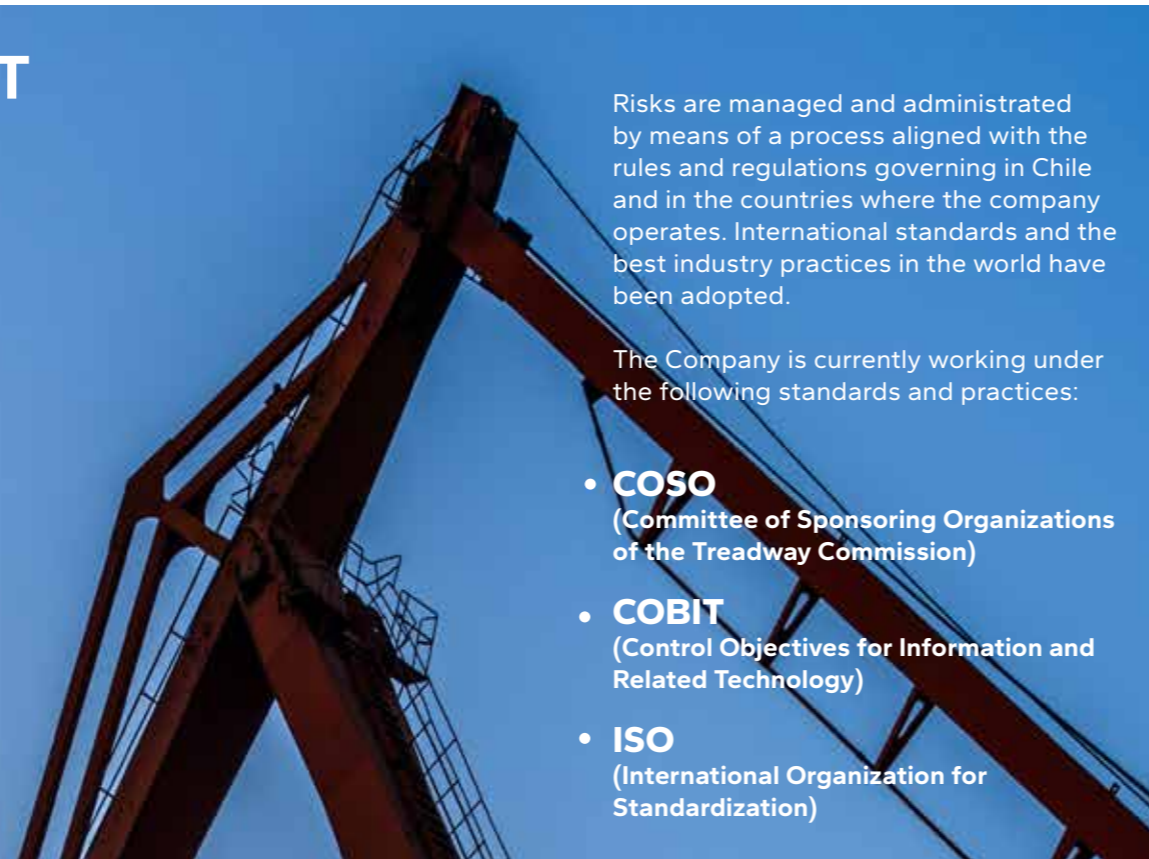



Risk Review

Sigdo Koppers maintains a robust risk review process to ensure informed decision-making and organizational resilience.

The key elements of this process include:



The Board of Directors of Sigdo Koppers S.A. is responsible among its functions for oversight the management of the risks managed by the risk committee of Sigdo Koppers S.A.

This last committee (second line, and made up of first line executives from Sigdo Koppers S.A.) is in charge of **setting control standards and oversees compliance with the risks of SK subsidiaries.**

The risks of SK subsidiaries are, in turn, monitored and managed by a committee of each SK subsidiary (7 in total, second line also but at the level of the operational companies, that is, the subsidiaries).

Then, each of the 7 SK subsidiaries has various Operational Risk Ownership (first line, risk managers and business unit heads) that own and manage risks in their respective areas, and that report to the risk committees of each subsidiary.

Finally, there is an Internal Audit Unit (third line) in charge of **verifying and providing independent assurance on the effectiveness of risk management and compliance processes, specifically towards the Risk Committees of Sigdo Koppers S.A. and the risk committees of each SK subsidiary.**

01. Risk Exposure Assessment:

The company regularly evaluates its exposure to relevant risks, taking into account both the likelihood and potential impact. This review is conducted at least twice a year—or more frequently when necessary.

02. Risk Appetite Framework:

A clear process is in place to define and review the company's risk appetite for each identified risk, helping guide strategic and operational decisions.

03. Mitigation Strategies:

For each relevant risk, specific actions are defined and implemented to minimize potential negative impacts.

04. Internal Audit of Risk Management:

Sigdo Koppers has conducted an internal audit of its risk management processes within the past two years to ensure their effectiveness and compliance.

05. Risk Culture:

The company actively promotes a strong risk culture throughout the organization by:

- Delivering targeted training on risk management principles
- Integrating risk criteria into the development of products and services
- Aligning financial incentives with risk management performance

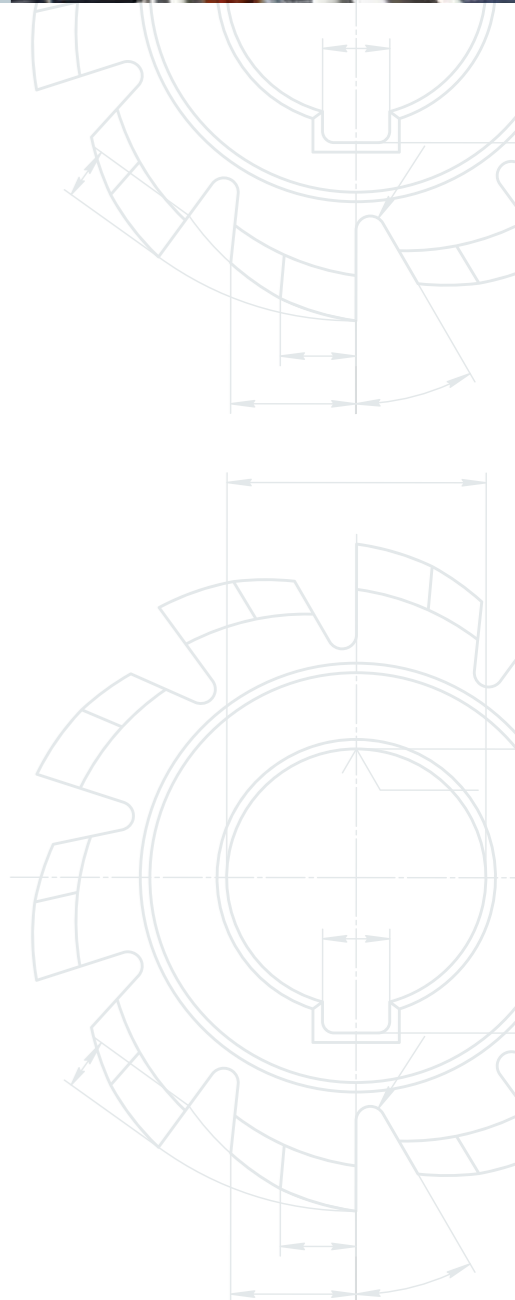

2024

Sigdo Koppers provided training in the Economic Crimes Law, the Crime Prevention Model, Cybersecurity and changes to the taxation system.



○ THE CONTINUOUS TRAINING OF EMPLOYEES IS A FUNDAMENTAL PILLAR OF THIS STRATEGY

As mentioned earlier, the adaptation of the Crime Prevention Model involved updating risk matrices to add potential risks of the crimes contained in Economic Crimes Law 21,595 and the risks of environmental damage.

This update strengthened risk management and improved the organization's ability to prevent and mitigate legal, operating and reputational impacts.

Please note that Sigdo Kopper's Risk Management Policy covers both environmental and social risks, including Human Rights (H.R.) risks. Social risks are managed by measurement, analysis and response processes; environmental and H.R. risks are being added under a new method and processes aligned with the requirements in General Rule 461 of the CMF. This includes due diligence reviews to evaluate and mitigate H.R. risks in the company's operations.

The company operates under a diversified business model, which helps significantly mitigate identified risks. To strengthen the resilience of its infrastructure and processes, the company is constantly incorporating the best practices throughout its value chain. The goal is to control and prevent deviations in planning and avoid regulatory, operating and strategic violations.

CLASSIFICATION OF risks

01.

Strategic:



These are risks related to the strategic goals aligned with the organization's Mission.

- Definition of the Strategy
- Mergers, Acquisitions and Joint Ventures
- Economic Cycle
- Dependence on Key Employees
- Reputation Risk
- Innovation and Development
- Human Rights
- Social Risks

02.

Operating:



These are risks arising from weaknesses or flaws in processes, people, systems or from external events. This category includes the risks related to Climate Change, both physical (flooding, mudslides, tidal waves and rising sea levels, droughts/water crises) and transitional.

- Risks of subsidiaries
- Systems and processes
- Cyber risks
- Fraud or illegal activities
- Climate Change
- Risks of regulatory and/or regulation compliance, such as: labor, tax, transfer pricing, environmental, competition and customs risks and risks involving the Financial Market Commission

03.

Financial:



These are risks related to an effective and efficient use of financial resources.

- Money Management
- Liquidity
- Bond covenant compliance

04.

Transition:



These are risks coupled with changing to an economy with low greenhouse gas emissions:

- Political and legal risks
- Reputation risks
- Technological risks
- Market risks

The company has a

Risk Committee

to guarantee an effective management. It must ensure that these processes are performed correctly and it must analyze the potential impacts of the business decisions of subsidiaries.

This committee is under the supervision of the Sigdo Koppers Board. It reviews risk management semi-annually to ensure that informed decisions are made in line with the corporate goals.

Like with the Risk Committee, the Sigdo Koppers Board supervises the risk management process implemented by management.

This responsibility entails:

- approval of the Risk Management Policy and Procedure
- defining and approving the risk profile and risk tolerance proposed by management and by the Risk Committee
- being informed of the organization's critical risks and of the progress in the pertinent action plans
- approving the annual budget for the critical risk action plans proposed by the Risk Committee
- evaluating and receiving recommendations from the Risk Committee on risk management.



The chief executive officer plays a key role in aligning the corporate strategy with risk management.

His duties include:

- fostering a "Control Culture" to ensure that the company's officers
- understand the importance of operating in a controlled environment
- ensuring compliance with the Risk Management
- Policy and Procedure understanding the levels of exposure and adequately managing identified risks
- supervising the implementation of action plans to mitigate critical risks
- ensuring that the company's risks remain within the tolerance limits approved by the Board
- appointing a Risk Management Officer validating and evaluating the main critical risks with senior management
- developing and maintaining governability mechanisms that facilitate effectively managing and monitoring the risks of Sigdo Koppers.

IN THIS RESPECT, THE COMPLIANCE AREA IS RESPONSIBLE FOR OVERSEEING REGULATORY COMPLIANCE, STRENGTHENING INTERNAL CONTROLS AND GUARANTEEING AN ADEQUATE RISK MANAGEMENT.

THE INTERNAL AUDITING UNIT VERIFIES THE EFFECTIVENESS OF THE POLICIES AND PROCEDURES IMPLEMENTED.

In 2024, Sigdo Koppers strengthened its organizational structure to improve risk management and optimize its capacity to respond to new challenges.

The company made the following changes as part of this strategy:

01. Creation of the Compliance Area:

to reinforce regulatory oversight and control throughout the organization.

02. Expansion of the Procurement Area:

to improve the efficiency and transparency of the acquisition of goods and services and ensure a greater control of operating and financial risks.

03. Creation of the Cybersecurity Department:

to address the growing technological risks and protect the company's digital assets.

These changes reflect Sigdo Koppers' commitment to continuous improvement, sustainability and risk management, strengthening its resilience to an increasingly more dynamic and regulated environment.

Sigdo Koppers has a Code of Corporate Ethics to aid in an appropriate management of regulatory risks, of employment practices and of relationships with stakeholders in general. The Code sets down a framework of behavior, regardless of the physical location where activities and duties take place. As mentioned earlier, the company also has a whistleblower channel where claims can be made directly or anonymously.

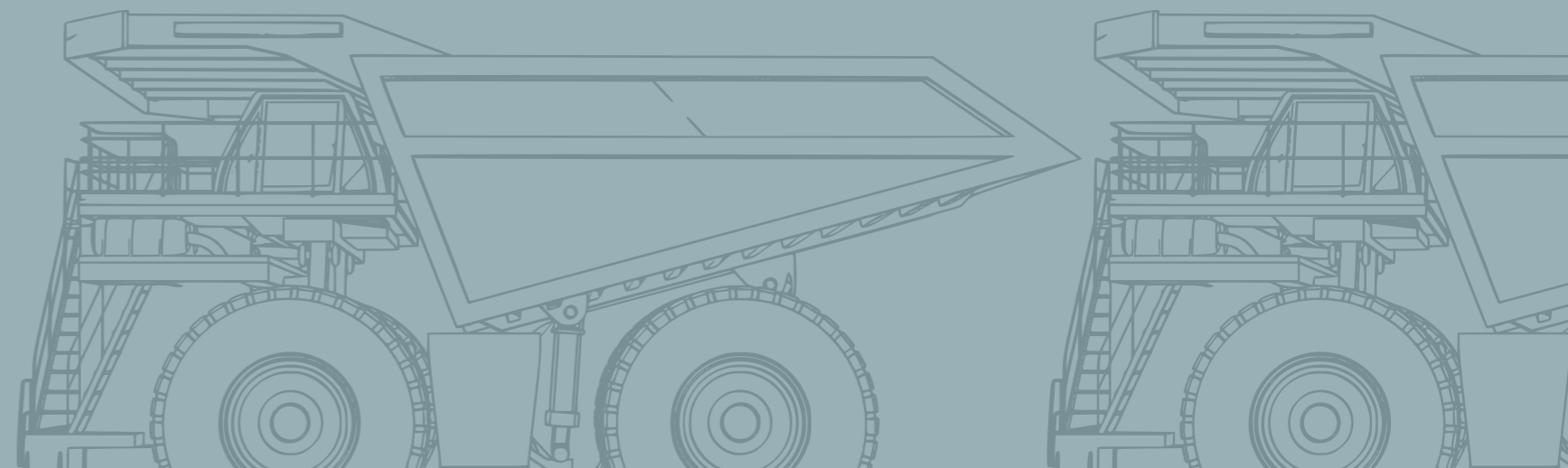

The company also has a risk management procedure that formalizes Corporate Governance practices in the company.

This document contains the main guidelines, roles and responsibilities of the individuals and bodies in charge of risk management. It specifies, among other things, that the:

<p>> Board of Directors</p>	<p>supervises the risk management process performed by management.</p>
<p>> Chief Executive Officer</p>	<p>must align the company's strategy to risk management.</p>
<p>> Risk Management Committee</p>	<p>plays an executive role.</p>
<p>> Risk Management Officer</p>	<p>coordinates, facilitates and collaborates in risk management activities.</p>
<p>> Process Owner</p>	<p>must identify the critical risks affecting Sigdo Koppers and ensure that they are managed adequately.</p> <p>They must therefore identify controls, self-evaluate and propose action plans.</p> <p>They must also coordinate on an ongoing basis with the Risk Management Officer and are directly responsible for risk management.</p>

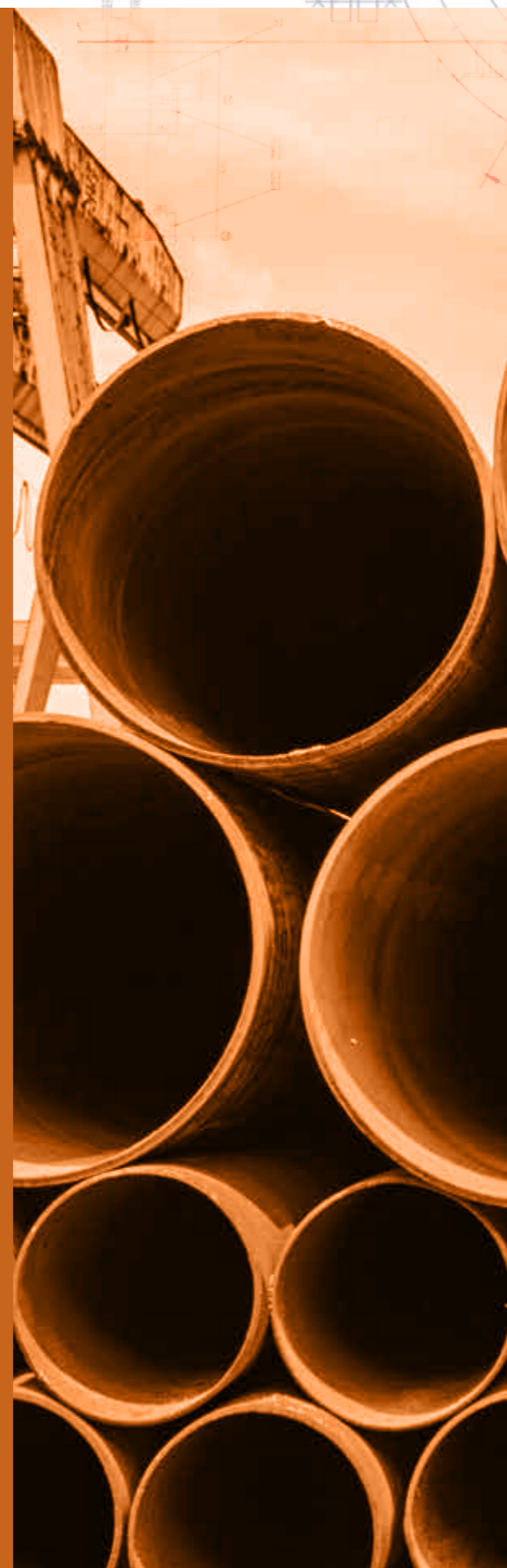

**SIGDO KOPPERS S.A.
MANAGES ITS
RISKS BY MEANS OF
CONTINUOUS ACTIONS
THAT ARE INTENDED
TO REDUCE THE
OCCURRENCE OF
RISKS AND MITIGATE
POTENTIAL
IMPACTS.**

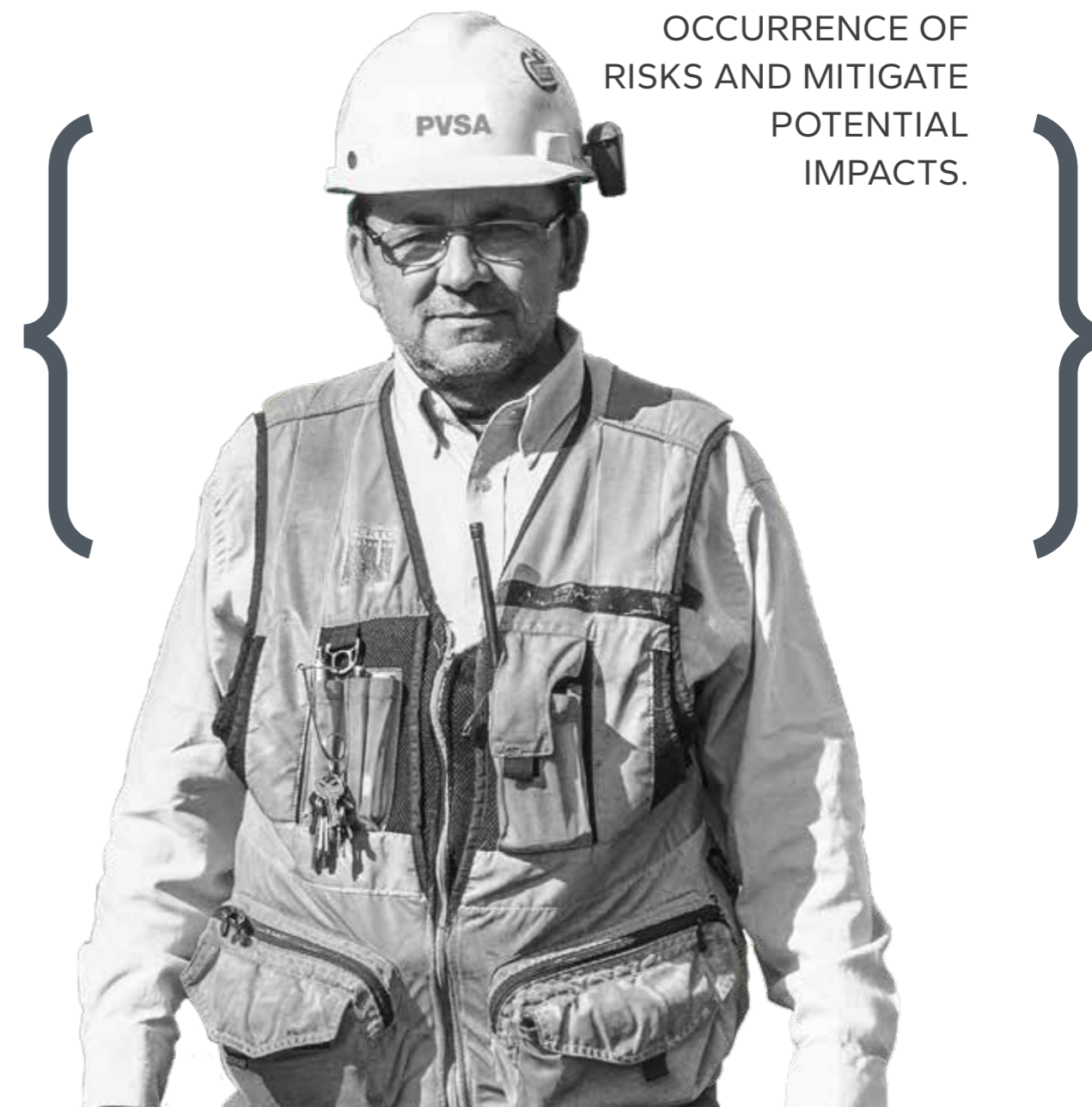

COMPLIANCE

Number of breaches in FY 2024 of Corruption or Bribery, Discrimination or Harassment, Customer Privacy Data, Conflicts of Interest, and Money Laundering or Insider trading

0

Sigdo Koppers has implemented a comprehensive, group-wide Anti-Bribery and Anti-Corruption Policy, demonstrating its firm commitment to ethical business conduct.

The policy includes the following key provisions:

- Clear measures to prevent bribery and corruption across all operations
- Guidelines for the appropriate handling of gifts, hospitality, and entertainment
- Rules governing political contributions
- Standards for charitable donations and sponsorships to avoid conflicts of interest
- Mandatory training programs to raise awareness and ensure compliance among employees
- Established procedures for reporting and managing any breaches of the policy
- Defined corrective and disciplinary actions in cases of non-compliance

The policy is formally endorsed by the Board of Directors, underscoring its importance at the highest level of corporate governance.

Whistleblowing Mechanism at Sigdo Koppers

Sigdo Koppers has a robust whistleblowing mechanism designed to uphold integrity and ensure accountability across the organization. The system allows for the identification, reporting, and investigation of breaches of the Code of Conduct, and includes the following key features:

A clearly designated department and/or individuals responsible for managing the whistleblowing process

A secure and independent reporting channel operated by a third party

The option for whistleblowers to report anonymously

Strict confidentiality measures to protect the identity and content of reports

A zero-tolerance policy for any form of retaliation against whistleblowers

Training provided to employees on how to use the reporting system effectively

Transparent procedures for how reported cases are investigated and managed

2024 Consolidated Contributions & Spending

Total Consolidated:

US\$ 962,849

Philanthropy:

US\$ 681,561

Trade Association:

US\$ 281,287

2024 Largest Consolidated Contributions & Spending to Trade Associations

01. Chilean Maritime and Port Chamber A.G. (CAMPORT): US\$ 48,781
02. Society for Industrial Development (SOFOFA): US\$ 36,385
03. Mejillones Industrial Association (AIM): US\$ 23,938
04. United Nations Global Compact: US\$ 14,363
05. Association of Businesses of the Valparaíso Region (ASIVA): US\$ 12,084

CIBERSECURITY



Sigdo Koppers Information Security Policy

Our Information Security Policy reflects Sigdo Koppers' commitment to safeguarding information across all levels of the organization. The policy is built on the following principles:

Continuously improving our information security systems to stay ahead of emerging threats

Ensuring the integrity and protection of data across all platforms

Proactively monitoring and responding to security risks and incidents

Defining clear responsibilities for every member of our workforce in maintaining information security

Establishing strict information security requirements for third-party partners and suppliers

Information Security Management Programs

At Sigdo Koppers, we take information security seriously. Our Information Security Management Program includes the following key components to protect our data, systems, and operations:

Business continuity plans that specifically address information security

Regular analysis to identify and address potential vulnerabilities

Internal audits of our IT infrastructure and security management systems

Independent external audits to ensure compliance with best practices (2024 IT Audit conducted by Deloitte, based on ISO 27001)

A clear escalation process for employees to report incidents, vulnerabilities, or suspicious activities

Ongoing awareness training to promote a strong security culture across the organization

6
Information Security Breaches in 2024

STRATEGY

THE COMPANY BASES IT MANAGEMENT ON A TRIPLE-BOTTOM-LINE STRATEGY THAT AIMS TO ACHIEVE THE BEST SOCIAL, ENVIRONMENTAL AND ECONOMIC PERFORMANCE AND A RESPONSIBLE, LONG-TERM GROWTH.

Environmental

Measure and reduce the environmental impact of operations and contribute to a balanced environment.

Social

Create value for employees, communities, suppliers, customers and authorities.

Economic

Attain good, stable economic results under a long-term vision.

STRATEGIC GOALS

In developing its businesses, Sigdo Koppers aims to grow profitably, continuously and sustainably. To achieve this, it has created a strategic agenda with 5 main goals.

Each of these goals is coupled with specific indicators and plans.

On a corporate level, Sigdo Koppers plans and manages its strategic goals in a stakeholder matrix. It wants to create permanent ties with stakeholders by creating advancements and adopting new planning and management methods.

01. Closeness with customers
02. Leadership and innovation of our companies
03. Global Reach
04. Financial soundness
05. Economic, social and environmental sustainability of operations

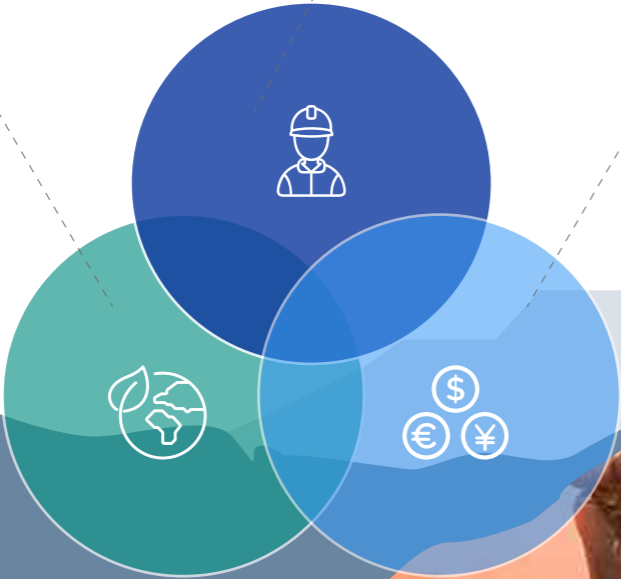

STAKEHOLDERS

The Sigdo Koppers Group has identified 6 priority stakeholders based on their influence and interest in the company and vice versa.

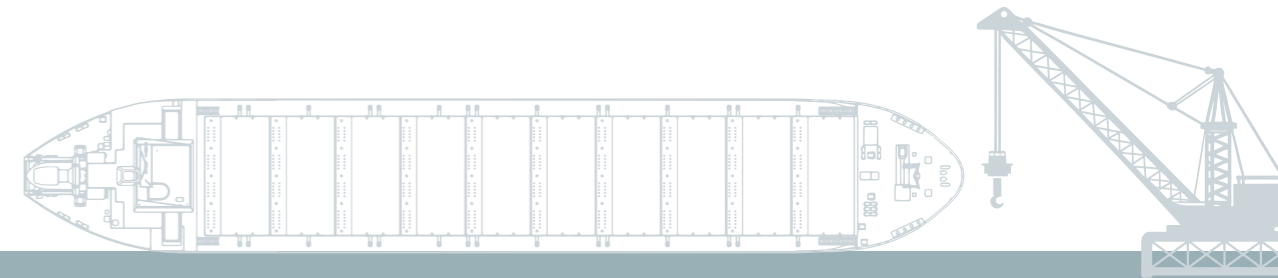

	Employees	Customers	Suppliers	Communities and Society	Authorities and Regulators	Investors and Financial Entities
Subgroup	<p>Employees Unions</p>		<p>Suppliers of goods and services Contractors</p>	<p>Locals Social leaders Families of employees Foundations NGOs Global and local associations Trade associations The media Universities Think tanks</p>	<p>Local and national authorities Regulators</p>	<p>Shareholders Investors Banks Other financial institutions</p>
Why are they relevant?	<p>The team is the basis for the organization's success.</p> <p>They give operations continuity and are key to the company's competitiveness.</p> <p>They are the visible face of the company to the other stakeholders.</p>	<p>Providing timely, competitive and efficient solutions is key to the sustainability of our businesses.</p> <p>Customers may reduce or increase the demand for the Group's products and services.</p> <p>They position the company reputationally and economically.</p>	<p>We endeavor to maintain long-term relationships with our suppliers in order to receive quality inputs as needed for our operations.</p> <p>Suppliers can impact the standards of the end product.</p>	<p>A close, constructive relationship with communities facilitates the continuity of operations and contributes to social progress.</p> <p>The relationship with civil society has a positive impact on reputation and on operations, and it is needed to ensure sustainability in the long term in a setting that has an ever greater appreciation for social responsibility and ethical commitment.</p> <p>Create strategic alliances to facilitate the development of knowledge and innovation needed for the companies to be competitive.</p>	<p>Their importance lies in the ability to grant the permits needed to operate or to revoke them whenever companies do not comply with governing regulations and/or violate human rights relating to care for the environment and setting.</p>	<p>They play a fundamental role as they can restrict or promote investments in projects that require a high level of confidence from the market and may impact the company's competitiveness.</p>
How do we relate?	<p>Across-the-board communication campaigns Internal communication channels Social networks Whistleblower channels Job Climate Surveys Performance evaluations Human Resource and Welfare Areas of the companies</p>	<p>Websites Social networks Advertising Annual Reports Brochures Satisfaction surveys Meetings</p>	<p>Websites Supplier portals Social networks Annual Reports Meetings</p>	<p>Websites Social networks Visits to plants Community celebrations Annual Reports Communications Areas Press Releases Trade association committees</p>	<p>Annual Reports Websites Informational letters</p>	<p>Websites Social networks Annual Reports Investor Relations Areas Shareholders Meetings Investor Day International Road Show Participation in conferences The media</p>
Owner area	<p>People Division</p>	<p>Commercial and Operations Divisions</p>	<p>Procurement Divisions</p>	<p>People, Sustainability, Innovation and Communications Divisions</p>	<p>Finance Division, Investor Relations, Comptroller</p>	<p>Gerencia de Finanzas, Relaciones con Inversionistas</p>

CONTRIBUTION TO THE SUSTAINABLE DEVELOPMENT GOALS (SDG)

Sigdo Koppers signed the U.N. Global Compact in 2007

The company's triple-bottom-line strategy is managed according to specific goals that are aligned with the U.N. Sustainable Development Goals (SDGs). They are part of the commitment adopted by the Chilean government in the 2030 agenda.

Under this compact, it has assumed the commitment to abide by and promote ten principles in the areas of human rights, labor relations, the environment and anti-corruption.

The company and its subsidiaries aim, through their programs and initiatives, to contribute to attaining the Sustainable Development Goals (SDGs), to improve the quality of life of people and to protect the environment.

AWARDS & CERTIFICATIONS

IN 2024, SIGDO KOPPERS AND ITS SUBSIDIARIES WERE HONORED WITH SIGNIFICANT AWARDS IN RECOGNITION OF THEIR MANAGEMENT PERFORMANCE.



Awards

- For the tenth consecutive year, Sigdo Koppers was selected to be part of the Dow Jones Sustainability Index Chile.
- Enaex Brazil was recognized with the SESI ODS Award for its commitment to sustainability and its contributions toward achieving the Sustainable Development Goals (SDGs).
- Enaex received the WIPO National Award for its consistent use of patents and promotion of innovation in Chile.
- Enaex was also honored with the Industry Safety Award by the Institute of Makers of Explosives (IME), highlighting its leadership in safety in the United States.
- Fepasa received the National Logistics Award in the category Regional Logistics Contribution for its MAPA Yard Control System. The award was granted by Conecta Logística and El Mercurio.
- SKIC Group received the Confederation of Production and Commerce of Chile (CPC) Award in the Major Projects category for the execution of Colbún's Horizonte Wind Farm, the largest of its kind in Latin America.
- For the seventh consecutive year, Enaex achieved first place in the Most Innovative Companies Ranking, in the category of Major Suppliers to the Mining Industry.

Environmental Certifications And Recognitions

Sigdo Koppers Group and its subsidiaries reinforce their commitment to sustainability and continuous improvement in environmental performance through the implementation, maintenance, and certification of internationally recognized management systems, as well as participation in national and international programs and recognition schemes. This commitment is reflected in a portfolio of certifications that address environmental, energy, climate, and water management, along with initiatives for decarbonization, operational efficiency, and sectoral leadership.

During 2024, the SK Group and its subsidiaries strengthened their environmental management through the following certifications and verification programs:

- ✓ **ISO 14001:2015 – Environmental Management Systems**
Subsidiaries operate with certified systems that structure processes aimed at regulatory compliance, control of significant environmental aspects, and continuous improvement of environmental performance.
- ✓ **ISO 50001:2018 – Energy Management Systems**
In operations with high energy consumption, certified systems have been implemented to enhance energy efficiency and reduce impacts associated with energy use.
- ✓ **ISO 14064-1:2018 – GHG Emissions Verification**
Subsidiaries quantify their greenhouse gas (GHG) emissions in accordance with this standard and the GHG Protocol. Emission inventories are externally verified by an independent third-party body, ensuring transparency and climate traceability.
- ✓ **HuellaChile Program – Chilean Ministry of the Environment**
All subsidiaries operating in Chile participate in the HuellaChile program. Emissions management efforts have been recognized with Quantification and Reduction seals for GHG emissions.
- ✓ **Product Carbon Footprint Certification**
The subsidiaries Magotteaux Andino, Enaex Chile, Fepasa, and PVSA participated in the Ministry's pilot program, obtaining product carbon footprint certification for selected strategic Codelco clients. These companies were recognized among the 20 pioneering participants in the program.
- ✓ **I-REC Certificates – Renewable Energy**
Magotteaux, Enaex, and PVSA hold I-REC certificates that validate the use of electricity from renewable energy sources.
- ✓ **Blue Certificate – Water Footprint Measurement (ISO 14046)**
The subsidiary PVSA obtained certification for the quantification of its water footprint, in accordance with ISO 14046.
- ✓ **EcoPorts Certification**
Renewed for the fifth consecutive cycle through 2026. This certification, granted by ECOSLC and verified by LRQA (Netherlands), recognizes environmental excellence in European ports.
- ✓ **EcoVadis Assessment – Bronze Medal**
Since 2022, Magotteaux has participated in the international EcoVadis sustainability assessment. In 2024, it reached the 76th percentile and received the Bronze Medal, with notable performance in environmental management, human rights, ethics, and sustainable procurement.
- ✓ **Carbon Neutral Certification – Prillex Zero (SGS Peru)**
Enaex Peru obtained carbon neutrality certification for its Prillex Zero product, manufactured using green hydrogen and ammonia.



- Fundación Educacional Chile Dual
- SK Capacitación
- Talcahuano Technical Training Center



- Diversity and Inclusion Policy
- New leaders and training programs



- Corporate environmental management program



- SK Capacitación programs
- Job retraining programs
- Hiring of local labor



- SK Godelius - SK Lab
- Robotics and teleoperation programs
- Process innovation
- Digital sales and services channels
- Digitalization of operations



- Circular economy
- Waste management



- CO2 reduction programs



- Corporate biodiversity and ecosystem program



- Good corporate governance practices and policies



- Participation in trade associations
- Public-private alliances
- Participation in the Global Compact

INNOVATION

Innovation is a central thrust in Sigdo Koppers' strategy

The company has proposed furthering it in each of its subsidiaries in order to give customers solutions of excellence, improve the safety and quality of life of employees, operating efficiency and the company's competitiveness.

Innovation challenges form a part of the Sigdo Koppers Risk Matrix and the Risk Committee is in charge of monitoring, evaluating, planning and managing diverse actions in this respect. In parallel, the company has an Innovation Committee that must address this matter in the Group's companies.

In 2024, developing innovative products, services and processes continued to be a priority focus and several initiatives were implemented in regard to operating safety, digitalization and the environment, among other aspects.



THE VALUE OF INNOVATION HAS A CROSS-CUTTING IMPACT ON THE ECONOMIC, SOCIAL AND ENVIRONMENTAL PILLARS THAT SIGDO KOPPERS HAS DEFINED AS FUNDAMENTAL TO ITS LONG-TERM SUSTAINABILITY



Innovation also facilitates addressing important aspects relating to the different stakeholders in a demanding and changing environment.

US\$ 22 million
was the consolidated investment in Research and Development Projects

32 thousand hours
were allocated to training in this subject

The number of people working on R&D rose to

124



pro grams

/ STRATEGY

PUERTO VENTANAS

Fire Protection System:

PVSA finished building its Fire Protection System in 2024, the only one in Chile that is automatic. Fiber optics were installed in all of the solid and liquid cargo conveyor belts by which the system raises temperature alarms based on the international standards NFPA 13 and NFPA 2. Depending on the temperature range reached by the belt, the system automatically stops belt operation or floods the potential incident zone, all without the intervention of people, which guarantees the safety of employees and facilities.

Tube belt conveyors:

PVSA implemented infrastructure for the conveyance of solid and liquid bulk under the greatest technology standard available in the world. It consists of 2.3 kilometers of tube belts to manage cargo hermetically, and of smart electric system technology that reduces wiring by 50%. This not only reduces risks and increases operational reliability but also signifies important savings and energy efficiency.

ENAEX

UG iTruck:

A telecommanded priming and loading solution for underground mining. The project was developed during 2024 and the first blast took place at El Teniente mine in January 2025. This truck means keeping people out of the most dangerous zone in underground mines.

CBS:

The first version of the Centralized Blasting System (CBS) was finished in 2024. It will allow for blasting in underground mines from a control room outside of the risky zones. This system was first implemented at an Australian mine at the end of 2024 and its use is expected to expand during 2025.

Prillex ECO2:

Blue ammonia is used in the production of ammonium nitrate. Optimized processes are utilized that minimize greenhouse gas emissions and energy consumption, which means offering the market a product with a lower carbon footprint. It is currently being used at CODELCO mines like Radomiro Tomic.

DT5GN:

An update of Davey Bickford machines (PU, DBD, Remote Blaster) to increase the speed at which detonators are programmed, with an improved interface and quicker triggering procedure, among other improvements. Prototype testing is currently under way at different mines around the world.

MAGOTTEAUX GROUP

Hybrid autonomous manufacturing:

In 2022, the Magotteaux Group began its journey toward hybrid autonomous manufacturing. It completed two Proof of Concept (PoC) tests in 2024 at each plant in Thailand and Mexico to help identify the right technologies and partner for implementation.

This initiative to transform to Industry 4.0 is centered on improving operating visibility, standardizing data compilation and optimizing production efficiency. These technologies are now being implemented and startup is planned for July 2025.

MagoSense:

This is a digital tool designed specifically for the mining industry, developed in collaboration with KIMA Process Control. MagoSense helps control the fill level of mills to avoid overloading and it better controls emptying. It also helps reduce the damage and wear of the lining, which improves the efficiency of mills and reduces unexpected idle times.

SK GODELIUS

Paranal Observatory telescope automation and control project:

Implemented at one of the four Very Large Telescopes at the Paranal Observatory of the European Southern Observatory (ESO), it entailed replacing the motors, reprogramming the control logic and designing a new HMI interface for the wire rack system. Considering each telescope individually, it is the second largest optical telescope in the world. Using the Very Large Telescope Interferometer (VLTI), the four telescopes have the same capacity to gather light from one single telescope 16 meters in diameter, becoming the largest optical instrument in the world.

Cargo bridge teleoperation project at the Port of Tocopilla:

SQM entrusted SK Godelius with the conceptual engineering, the project and the implantation of a teleoperation system for its cargo bridge at the Port of Tocopilla. The project also includes building the Teleoperation Center where the bridge will be remotely operated.

Overland conveyor robotic inspection project at Los Bronces, of Anglo American:

This consists of a Proof of Concept for a system of robotic inspection of a critical belt in the operation of the Los Bronces mine. Several mobile robotic platforms are being used in the project, including four-leg platforms and wheeled platforms in which "Godelius X" will be utilized. Data are gathered through thermal imaging cameras and audio sensors and processed by the SK Godelius software and algorithms, which can then be used to anticipate potential breakdowns along the belt.

Project on automation and robotization of Face Preparation in building tunnels, for Vale in Sudbury, Canada:

This is a consultancy project in which a new technological paradigm is proposed for the automation and robotization of a risky, complicated process that is on the critical path in operation progress. The challenge and the solution proposed are applicable to the particular case of Vale, and to a good part of underground mining.

INNOVATION 2024

**INVESTMENT PLANS
FALL WITHIN THE
FRAMEWORK OF
SIGDO KOPPERS'
DEFINITION OF
ALWAYS HAVING
INVESTMENT
PROJECTS,
AND THEY ARE
FOCUSED BOTH ON
CHILE AND ABROAD
GIVEN THE GLOBAL
NATURE OF THE
COMPANY, WHICH
HAS OPERATIONS
IN AMERICA, ASIA,
EUROPE, AFRICA
AND OCEANIA.**



ECONOMIC PERFORMANCE

THE CHILEAN ECONOMY CONTINUED TO FACE A COMPLEX SETTING. IT GREW MODERATELY, PRODUCTIVITY WAS LOW AND THERE WAS A HIGH LEVEL OF GOVERNMENT DEBT. AND THE INTERNATIONAL SCENE WAS NOT THREAT-FREE, MAINLY BECAUSE OF THE VOLATILITY OF COUNTRIES IMPORTANT TO SIGDO KOPPERS AND BECAUSE OF GEOPOLITICAL TENSIONS.

In Sigdo Koppers' Industrial Area,

Enaex S.A. ended the year with a solid performance, growing in virtually all the regions where it operates. Magotteaux Group S.A. experienced a drop in income, partially due to temporary operating difficulties combined with market conditions that were more challenging than in recent years.

In the Commercial Area,

SKC S.A. showed signs of recovery in 4Q24 due to a great dynamism of the truck and machinery distribution business

In the Group's Services Area,

the performance of Ingeniería y Construcción Sigdo Koppers Group S.A. (SKIC Group), Puerto Ventanas S.A. (PVSA) and Ferrocarril del Pacífico S.A. (Fepasa) was poorer. In the first half of 2024, the two latter companies underwent a transition to a normalized operation and the trend in Fepasa's income has been rising since 3Q24.

US\$ **535** US\$ **103**

million

was the consolidated EBITDA in 2024, reflecting the earnings from the divestment of SK Mobility.

million

was the net profit in 2024. Noteworthy was having met the goal, self-imposed a year ago, of reducing working capital and net finance expenses.



INCOME DISTRIBUTION IN 2024

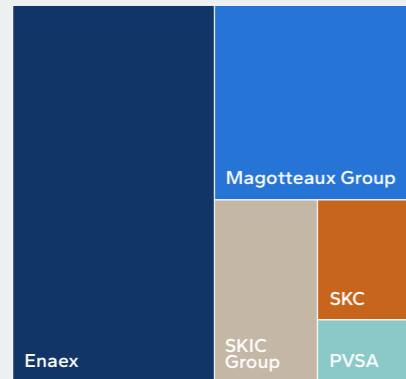

Income by Business (MUSD)

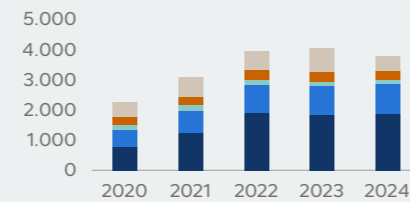

EBITDA by Business (MUSD)

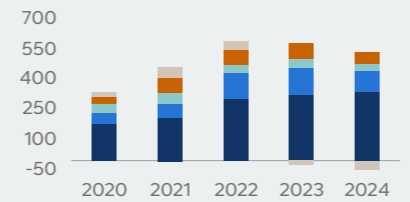

Trend in the ROE (%)

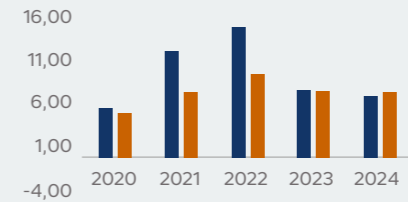

PROFIT ATTRIBUTABLE TO SK

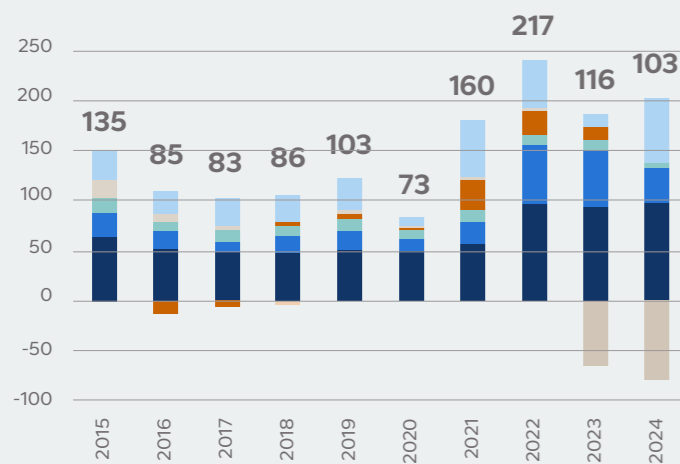

Consolidated SK (MUSD)



Trend in the Stock Price



P/E (times)

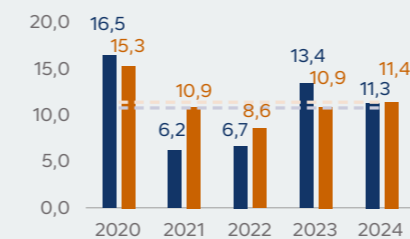

P/BV (times)

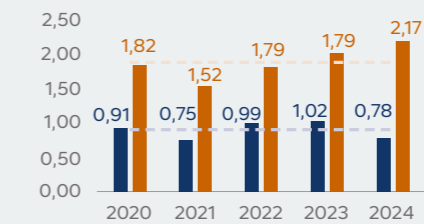



Income: The company's income rose in 2024, reflecting the increase in physical sales and the drop in the average price of NH3 year over year. Since the great majority of sales is made under contracts with indexation polynomials, the gross margins per ton have remained the same.

EBITDA: The company's EBITDA has continued in a positive trend, increasing 4.0% in the last twelve months, which would be sustained by the consolidation of the new subsidiaries acquired in recent years and by a gradual increase in global market share. We can mainly highlight the growth in the EBITDA in Peru, Chile Services, Africa and MTi.

Profit: The net profit of the controller continued upwards, growing 4% YOY, a reflection of resilient and sustained operating income and of an adequately healthy debt profile, which has helped maintain a sound ROE of 19.1%.

	2022	2023	2024
Statement of Income (USD 000's)			
Income	1,949,907	1,848,440	1,916,021
EBITDA	308,414	326,676	339,697
Controller's Net Profit	159,155	153,694	160,430
YOY Growth (%)			
Income	51.7%	-5.2%	3.7%
EBITDA	45.8%	5.9%	4.0%
Controller's Net Profit	70.6%	-3.4%	4.4%
Margins (%)			
Margen EBITDA	15.8%	17.7%	17.7%
Controller's Net Profit Margin	8.2%	8.3%	8.4%
Debt (times)			
Net Debt to EBITDA	1.16	1.1	0.87
Cinterest coverage	23.58	17.47	18.33
Profitability (%)			
ROE	20.9	18.5%	19.1%
ROIC	13.0%	12.2%	13.2%



Income: The company's income remained stable in 2024, mainly because of an increase in physical sales and lower average prices of grinding balls and castings.

EBITDA: The EBITDA decreased 16.8% YOY in the same period, mainly due to a lower gross margin on grinding balls—because of market forces and non-recurrent events in Canada and South Africa—and lower castings volumes, combined with a comparatively higher base as a result of extraordinary earnings in 4Q23.

Profit: The net profit of the controller fell 36.3% YOY, more than the decrease in the EBITDA in the same period, because of a higher depreciation and a decline in non-operating income.

	2022	2023	2024
Statement of Income (USD 000's)			
Income	908,000	973,989	966,992
EBITDA	120,692	127,104	105,710
Controller's Net Profit	59,532	56,926	36,285
YOY Growth (%)			
Income	26.6%	7.3%	-0.7%
EBITDA	82.4%	5.3%	-16.8%
Controller's Net Profit	166.1%	-4.4%	-36.3%
Margins (%)			
EBITDA Margin	13.3%	13.0%	10.9%
Controller's Net Profit Margin	6.6%	5.8%	3.8%
Debt (times)			
Net Debt to EBITDA	1.34	1.43	1.90
Interest coverage	10.21	7.43	6.11
Profitability (%)			
ROE	8.2%	7.5%	4.9%
ROIC	6.4%	6.1%	4.8%



Income: Income declined 2.4% YOY in 2024. Both 2023 and 2024 were abnormal years for Puerto Ventanas and Fepasa because their businesses were in a transition toward a normalized operating system after the losses suffered in 2022 and 2023, accompanied by the investments being made to recondition Port Andino in Mejillones. The seasonality of income is mainly the result of an increase in extraordinary income from insurance in 2023, from reconstruction stages and from non-recurrent accounting impacts.

EBITDA: The EBITDA decreased 35% YOY, partially due to Other Income recorded in 4Q23 as a result of the revaluation of the assets reconstructed after being damaged. Of note is the rising trend in the income of Fepasa—a PVSA subsidiary—since 3Q24.

Profit: The net profit of the controller declined 70.5% YOY, reflecting a drop in the EBIT and an increase in finance expenses, mainly in relation to an increase in the debt needed to recondition Port Andino in Mejillones.

	2022	2023	2024
Statement of Income (USD 000's)			
Income	164,311	155,700	151,993
EBITDA	44,544	52,375	34,060
Controller's Net Profit	16,623	21,597	6,361
YOY Growth (%)			
Income	-3.9%	-5.2%	-2.4%
EBITDA	-17.5%	17.6%	-35.0%
Controller's Net Profit	-32.0%	29.9%	-70.5%
Margins (%)			
EBITDA Margin	27.1%	33.6%	22.4%
Controller's Net Profit Margin	10.1%	13.9%	4.2%
Debt (times)			
Net Debt to EBITDA	2.05	2.55	5.43
Interest coverage	9.24	6.55	3.60
Profitability (%)			
ROE	12.8%	15.4%	4.7%
ROIC	8.6%	9.5%	4.6%





Income: The company's income declined 35.5% YOY in 2024, mostly because of the decrease in the backlog seen in the last few quarters and in physical sales and the seasonality inherent to project billing.

EBITDA: The EBITDA experienced a significant drop in 2024 that consisted of a decrease in gross earnings (-29%), mainly impacted by the re-measurement of work in previous years. Merely by way of example, the Pro Forma EBITDA of SKIC Chile, which only includes work after the date of implementation of the action plan, totaled approximately US\$20 million in 2024, revealing the effectiveness of the corrective measures adopted.

Profit: The net profit of the controller also contracted significantly YOY, mainly because of negative operating income that was partially offset by a reduction in net finance expenses.

	2022	2023	2024
Statement of Income (USD 000's)			
Income	610,734	727,659	469,313
EBITDA	40,984	-26,289	-45,929
Controller's Net Profit	3,713	-78,748	-83,565
YOY Growth (%)			
Income	-3.3%	19.1%	-35.5%
EBITDA	-3.5%	n.a	n.a
Controller's Net Profit	269.9%	n.a	n.a
Margins (%)			
EBITDA Margin	6.7%	-3.6%	-9.8%
Controller's Net Profit Margin	0.6%	-10.8%	-17.8%
Debt (times)			
Net Debt to EBITDA	4.70	n.a	n.a
Interest coverage	2.07	n.a	n.a
Profitability (%)			
ROE	3.8%	n.a	n.a
ROIC	8.6%	n.a	n.a



Income: At the close of 2024, the company's income had fallen 11.2% YOY, mainly as a result of a drop in income from the rental business in Chile and Colombia and a lower level of sales in the distribution business as a result of a reduction in the number of units sold, in line with the slowdown in the economy in 2023-24 compared to 2021-22.

EBITDA: In 2024, the EBITDA fell 31.2% YOY, mainly because of a decrease in gross earnings due to excessive stock on the market and a contraction in demand. A recovery is expected in 2025 based on better economic outlooks.

Profit: SKC suffered a net loss of US\$1.9 million in 2024 as a result of a decline in operating income combined with higher non-operating losses because of uncollectible receivables, mainly in Colombia. This was partially offset by a reduction in finance expenses.

	2022	2023	2024
Statement of Income (USD 000's)			
Income	324,742	322,024	286,022
EBITDA	71,335	70,327	48,367
Controller's Net Profit	29,406	14,338	-1,914
YOY Growth (%)			
Income	4.2%	-0.8%	-11.2%
EBITDA	-5.8%	-1.4%	-31.2%
Controller's Net Profit	-15.6%	-51.2%	-113.3%
Margins (%)			
EBITDA Margin	22.0%	21.8%	16.9%
Controller's Net Profit Margin	9.1%	4.5%	-0.7%
Debt (times)			
Net Debt to EBITDA	2.22	2.68	3.03
Interest coverage	8.04	3.85	2.97
Profitability (%)			
ROE	20.3%	9.8%	n.a
ROIC	12.6%	9.0%	5.0%



SOCIAL PERFORMANCE

ALCANZAR LOS MEJORES RESULTADOS EN EL ÁMBITO SOCIAL ES UNO DE LOS OBJETIVOS DE NEGOCIO DE SIGDO KOPPERS S.A. LA COMPAÑÍA BUSCA GENERAR VALOR COMPARTIDO CON TODOS SUS GRUPOS DE INTERÉS, HACIA QUIENES SE ALINEAN TODAS LAS ACTIVIDADES DE LA COMPAÑÍA.

• Employees

Organizational climate
Talent and succession
Gender equality
Zero accident rate

• Customers

Net Promoter Score (NPS) surveys
Sigdo Koppers Group synergies

• Suppliers

Incorporation of ESG standards to selection and evaluation
SMB early payment policies

• Investors and Financial Entities

Timely information:
presentations, conferences, meetings, website

Scheduled visits to subsidiaries' facilities

• Authorities and Regulators

Ongoing update of the regulatory framework

• Communities and Society

Update of the community maps of subsidiaries
Design of an engagement strategy
Perception study
Scheduled visits to facilities
Dual Technical Education Program: impact indicator
Alliances
Map of relationships with trade associations



HUMAN RIGHTS POLICY

Sigdo Koppers has a company-wide Human Rights Policy that reflects its strong commitment to upholding and promoting human rights in all aspects of its operations.

The policy includes the following key elements:

01. Commitment to International Standards:

A formal statement of commitment to respect human rights in line with internationally recognized frameworks and principles.

02. Protection of Fundamental Rights.

The policy explicitly includes the prevention of and respect for:

- Human trafficking
- Forced labor
- Child labor
- Freedom of association
- The right to collective bargaining
- Equal remuneration
- Non-discrimination

03. Scope of Application:

Applies to the company's own operations, including employees, business activities, products, and services

Sets clear expectations for suppliers, requiring alignment with the same human rights standards



EMPLOYEES

Employees are, to Sigdo Koppers, a fundamental pillar in the company's development and sustainability. They are the ones who generate innovative ideas, execute the strategies and give life to the projects driving the organization's growth. Their abilities and commitment are determining to achieving the goals and overcoming the challenges that arise.

For that reason, one of our principal objectives, as the parent company of the Sigdo Koppers Group, is to convey the Values and foster a shared organizational culture that guides the decisions and strategies in each of our subsidiaries and enables us not only to attain positive yields but also to constantly evolve while staying competitive, innovative, responsible and successful in the long term.

Employees also play a crucial role in creating sound relationships with customers, suppliers and other stakeholders, which helps establish strategic alliances valuable not only to the company's progress but also to the places where we are present.

We have constantly emphasized over the years forming committed, highly trained teams, which has been essential to achieving success in implementing our strategy.

In our management, we encourage a respect for the rights of our employees through the Code of Corporate Ethics and our Human Rights, Workplace and Sexual Harassment, and Equal Pay policies.

THIS CHAPTER REPORTS THE INFORMATION ASSOCIATED WITH THE TAXPAYER IDENTIFICATION NUMBER OF SIGDO KOPPERS S.A., THE PARENT COMPANY OF THE GROUP AND AN INVESTOR, WHICH EMPLOYS A LIMITED STAFF OF 29 WHO WORK IN THE CORPORATE BUILDING. SOME IMPORTANT INFORMATION ON SUBSIDIARIES IS ALSO INCLUDED BY WAY OF SUPPLEMENT.



Labor Practices Commitment at Sigdo Koppers

Sigdo Koppers is committed to upholding labor rights across all its operations, ensuring fair and responsible working conditions at the group-wide level. This commitment includes the following key practices:

- Paying a living wage that meets workers' basic needs and supports a decent standard of living
- Avoiding or minimizing excessive working hours, promoting work-life balance
- Establishing clear limits on maximum working hours in line with labor regulations and best practices
- Ensuring equal pay for equal work, regardless of gender
- Providing paid annual leave as a fundamental labor right

No penalties were enforced against Sigdo Koppers S.A. in 2024 in connection with employees, nor were any labor lawsuits filed against it.

OUR ORGANIZATIONAL CULTURE IS A KEY ENGINE IN ADAPTING TO THE NEW CHALLENGES AND TAKING ADVANTAGE OF THE OPPORTUNITIES ARISING

NOT ONLY AT THE PARENT COMPANY LEVEL BUT ALSO IN ALL SUBSIDIARIES COMPRISING THE SIGDO KOPPERS GROUP.

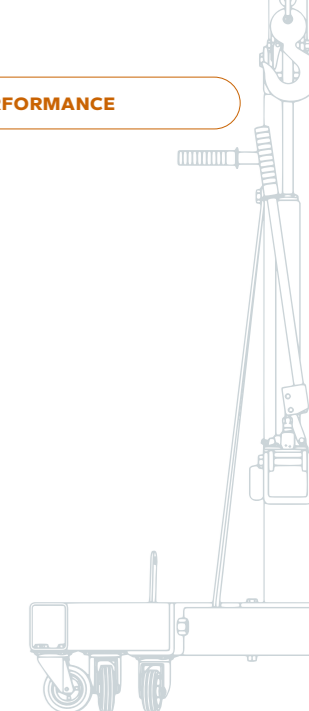
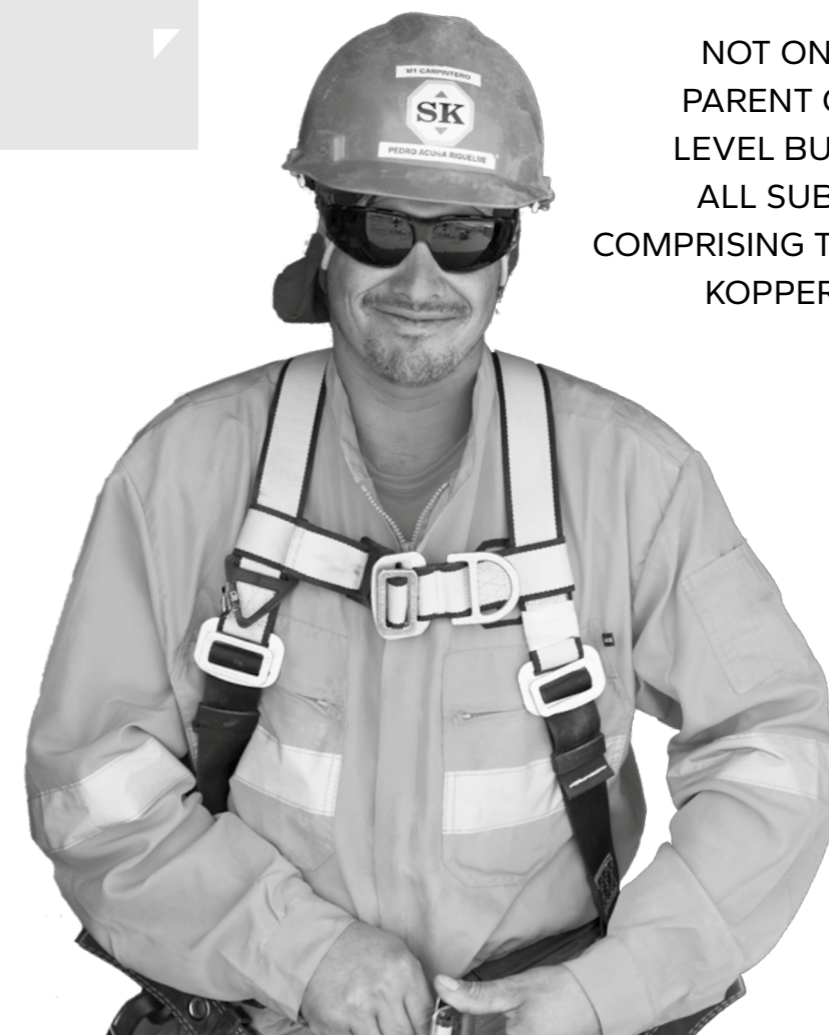

Number of Employees

} **17,443**
 is the total number
 of employees
 of Sigdo Koppers and
 consolidated subsidiaries
 SIGDO KOPPERS GROUP



Number of people
by sex

Position	SIGDO KOPPERS PARENT COMPANY	
	Women	Men
Upper Management	0	3
Management	4	2
Supervisors	2	0
Administrative Staff	0	1
Ancillary Employees	0	5
Other Professionals	9	3
Total	15	14

Sigdo Koppers S.A., the parent company, does not employ any manual workers, salesforce or other technicians, so they are not reported.

Number of people
by nationality

Position	SIGDO KOPPERS PARENT COMPANY							
	Chilean		Colombian		Venezuelan		Total	
	Women	Men	Women	Men	Women	Men	Women	Men
Upper Management	0	3	0	0	0	0	0	3
Management	4	2	0	0	0	0	4	2
Supervisors	1	0	0	0	1	0	2	0
Administrative Staff	0	1	0	0	0	0	0	1
Ancillary Employees	0	5	0	0	0	0	0	5
Other Professionals	8	3	1	0	0	0	9	3
Total	14	13	1	0	1	0	16	13

Number of Employees
by Region /

SIGDO KOPPERS GROUP

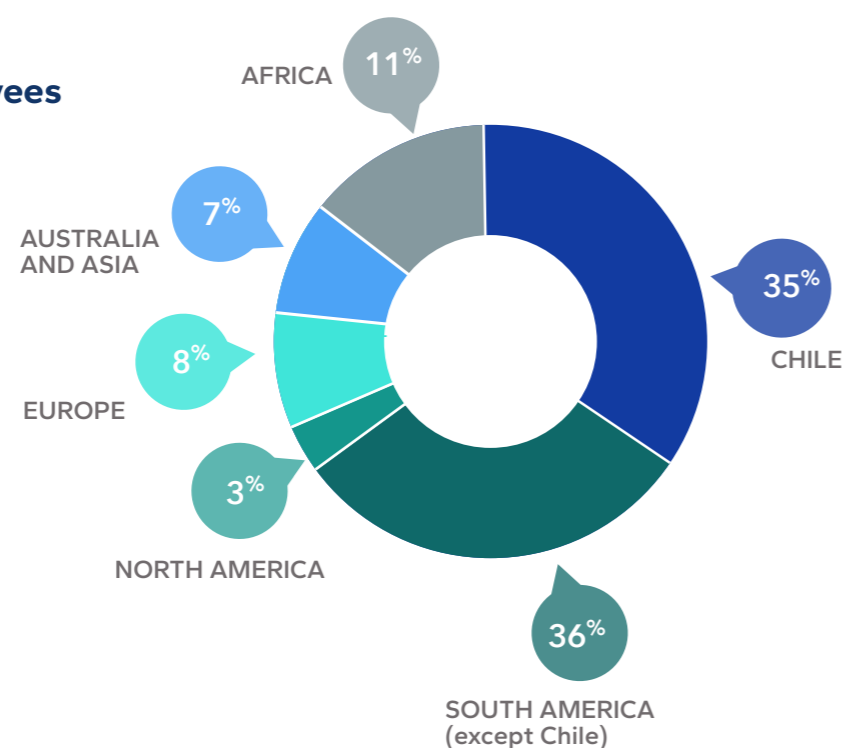

Number of people
by age range

Position	SIGDO KOPPERS PARENT COMPANY													
	< 30 years of age		From 30 to 40 years of age		From 41 to 50 years of age		From 51 to 60 years of age		From 61 to 70 years of age		Older than 70		Total	
	Women	Men	Women	Men	Women	Men	Women	Men	Women	Men	Women	Men	Women	Men
Upper Management						1				2			-	3
Management		1	1	1	3								4	2
Supervisors			2										2	-
Manual Workers													-	-
Salesforce													-	-
Administrative Staff										1			-	1
Ancillary Employees					1					4			-	5
Other Professionals	3	1	3	1			1	1	2				9	3
Other Technicians													-	-
Total	3	2	6	2	3	2	1	1	2	7	-	-	15	14

Labor Practices Programs

Sigdo Koppers has implemented comprehensive programs to ensure fair, safe, and respectful working conditions across its operations.

These programs include the following key practices:

- Ensuring fair wages, aligned with or above recognized cost-of-living benchmarks
- Monitoring working hours and managing overtime to prevent excessive workloads
- Guaranteeing proper compensation for overtime work in compliance with labor standards
- Maintaining regular dialogue with workers' representatives to address and improve working conditions
- Monitoring and addressing the gender pay gap to promote equal pay for men and women
- Ensuring employees take their paid annual leave, supporting rest, well-being, and work-life balance

SHARE OF WOMEN IN TOTAL WORKFORCE
(AS % OF TOTAL WORKFORCE):

16%

Share of women in top management positions, i.e. Maximum two levels away from the ceo or comparable position (as % of total top management positions):

16%

Share of women in junior management positions, i.e. first level of management (as % of total junior management positions):

19%

Share of women in all management positions, including junior, middle and top management (as % of total management positions):

18%



Number of people by time of employment

Position	SIGDO KOPPERS PARENT COMPANY											
	< 3 years		From 3 to 6 years		From 6 to 9 years		From 9 to 12 years		>12 years		Total	
	Women	Men	Women	Men	Women	Men	Women	Men	Women	Men	Women	Men
Upper Management		1								2	-	3
Management	2	1	1	1	1						4	2
Supervisors	1						1				2	-
Manual Workers											-	-
Salesforce											-	-
Administrative Staff									1		-	1
Ancillary Employees		1		1						3	-	5
Other Professionals	3	2	2		1				3	1	9	3
Other Technicians											-	-
TOTAL	6	5	3	2	2	-	1	-	3	7	15	14

Types of Contracts

Number of Employees by Sex and Type of Contract	SIGDO KOPPERS PARENT COMPANY				
	Hombres	Women	Total	% Men	% Women
Indefinido	14	15	29	48%	52%

SIGDO KOPPERS GROUP

Type of Contract%	% Trabajadores
Continuing	82%
Per Project or Site	13%
Fixed-Term	5%

Sigdo Koppers has no part-time employees, flexible arrangements due to family needs or reduced working hours to care for children under the age of 12, so no such information is reported.

Flexible Work Arrangements

Employees and Work Schedule	SIGDO KOPPERS PARENT COMPANY				
	Men	Women	Total	% Men	% Women
Regular working hours (full-time)	14	15	29	48.3%	51.7%
Telecommuting Employees	SIGDO KOPPERS PARENT COMPANY				
	Men	Women	Total	% Men	% Women
Number of employees telecommuting	3	8	11	27.3%	72.7%

Diversity

Sigdo Koppers believes that diversity helps foster an environment of innovation, creativity and growth.

Companies that have diverse teams can address challenges from multiple perspectives, which facilitates designing more complete solutions adapted to global needs. Diversity not only enriches decision-making but also promotes an inclusive climate in which all employees feel appreciated and respected, which increases motivation, commitment and organizational wellbeing.

Pay Gap

We have an Equal Pay Policy where the goal is to guarantee that all our employees earn a fair salary appropriate to their position, functions, education and skills without any discriminatory factors intervening.

This policy sets down clear directives for all of the Group's subsidiaries regarding compensation programs and systems, always under the principle of equal pay for individuals holding the same position and having the same responsibilities. In addition, the Group's companies conduct performance evaluations each year and studies on the industry's salary standards so that they can apply fair and objective criteria in this respect.

In the case of Sigdo Koppers S.A., the pay gap (women's gross salary/men's gross salary) does not apply to the categories of Upper Management, Supervisors, Administrative Staff or Ancillary Staff because the employees in those categories are all of the same sex. There is no pay gap by gender for the categories of Management and Other Professionals because no woman or man holds the same position or has the same responsibilities or duties.

Inclusión

Including people with disabilities in the Sigdo Koppers Group has been highly important to promoting a diverse, equitable and respectful organizational culture that appreciates the abilities and skills of all employees, regardless of their limitations. By integrating people with disabilities, companies not only fulfill their social responsibility but also enrich the work environment by new perspectives and innovative approaches. This inclusion fosters a climate of respect and empathy, contributes to the internal climate and strengthens the sense of belonging.

The company has implemented inclusion programs in its subsidiaries with great results. The operations in Chile have been implementing the Chile Valora (Chile Values) program for years, which aims to formally recognize the knowledge and skills of people who have a trade, which works in favor of their employability.

Sigdo Koppers S.A. has no disabled employees.

Discrimination & Harassment Policy

Sigdo Koppers has a comprehensive, group-wide policy that reinforces its commitment to a respectful, inclusive, and safe workplace.

The policy includes the following key measures:

- Explicit prohibition of all forms of harassment, including:
 - Sexual harassment
 - Non-sexual harassment (e.g., bullying, intimidation)
- Zero-tolerance policy toward any form of discrimination based on gender, ethnicity, age, religion, disability, or other protected characteristics
- Mandatory training for all employees to raise awareness and prevent discrimination and harassment in the workplace
- A clear escalation and reporting process specifically designed for incidents related to discrimination or harassment
- Corrective or disciplinary actions are taken promptly when violations occur, reinforcing the company's commitment to accountability and safe work environments



Workplace and sexual harassment

The Sigdo Koppers Group rejects any workplace and sexual harassment of its employees, so it has formal policies, complaint and resolution mechanisms that are intended to eliminate this conduct contrary to the company's Values.

The company has a Code of Ethics, among other internal policies and regulations, that contains the directives and procedures to avoid any type of workplace or sexual harassment, as well as a Whistleblower Channel to handle potential harassment.

Unions

Sigdo Koppers encourages a constructive, open dialog between companies and the unions representing their employees in order address employee concerns and needs efficiently, which helps strengthen their commitment to the organization's objectives. In addition, a solid relationship with unions facilitates resolving disputes early, avoiding tensions and promoting stability inside the company.

Given the number of employees that it has, there are no unions or collective bargaining agreements in Sigdo Koppers S.A. In contrast, given the number of their employees, subsidiaries have collective bargaining agreements in place and unions.



THE COMPANY HAS A CODE OF ETHICS, AMONG OTHER INTERNAL POLICIES AND REGULATIONS, THAT CONTAINS THE DIRECTIVES AND PROCEDURES TO AVOID ANY TYPE OF WORKPLACE OR SEXUAL HARASSMENT, AS WELL AS A WHISTLEBLOWER CHANNEL TO HANDLE POTENTIAL HARASSMENT.

In 2024, **55%** of employees of Sigdo Koppers S.A. received training in the prevention of sexual and workplace harassment and workplace violence and in the investigative procedures and penalties should this conduct occur in the company.

No complaints of this type were made in 2024 to the Labor Bureau or to the company.

Percent of employees represented by an independent trade union or covered by collective bargaining agreements:

48%



Occupational Health and Safety



Work-related fatalities for **employees:**

2

Work-related fatalities for **contractors:**

0

Lost-Time Injury Frequency Rate in 2024 with **100% data coverage:**

4.5



Occupational health and safety are fundamental aspects of the management of Sigdo Koppers because we believe that a safe work environment is key to the wellbeing of our employees and to the long-term success of the company.

Risk prevention is a priority in all our operations. We therefore have a corporate policy that regulates these practices around the world. Each of the Group's companies also implements their own monitoring procedures and systems to ensure the safety of their employees.

Our goal is clear: zero accidents. To achieve this, the results of the actions and measures taken are analyzed monthly by the Board, which means that we evaluate safety performance and can make changes whenever necessary.

The company also has Internal Rules on Order, Hygiene and Safety that regulate all aspects of safety and risk prevention at work. These rules guide the behavior and practices of all employees to ensure that each person understands and follows the appropriate procedures to avoid accidents and promote a culture of safety at all times.

There were no work-related accidents, illnesses or fatalities in 2024 at Sigdo Koppers S.A.

Occupational Health and Safety (OHS) Commitment

Sigdo Koppers demonstrates its strong commitment to Occupational Health and Safety (OHS) through its Internal Rules on Order, Hygiene, and Safety, which guide the company's practices and performance across all operations. SK companies, in turn, have their own OHS policies tailored to the specific needs of each business/operation, which include the following key aspects:

Implementing these measures reinforces our commitment to the health and wellbeing of our employees and enables us to operate responsibly and efficiently while caring for both our people and the environment in which we work.

- 01. Comprehensive Scope:** The policy applies to all company operations, covering both employees and contractors or individuals under the company's supervision.
- 02. Regulatory Alignment:** Ensures compliance with applicable international OHS standards, national regulations, voluntary programs, and collective labor agreements related to health and safety.
- 03. Continuous Improvement:** Includes a formal commitment to continually enhance the performance of the OHS management system.
- 04. Risk-Based Action Plans:** Establishes clear prioritization criteria and action plans to address health and safety risks effectively.
- 05. Quantitative Targets:** Defines measurable goals to track and improve OHS performance indicators over time.
- 06. Governance and Endorsement:** The implementation of the OHS policy is formally endorsed by Executive Management, underscoring its strategic importance to the organization.

SK companies' OHS programs consider/cover the following:

- OHS risk and hazard assessments to identify what could cause harm in the workplace.
- Prioritization and integration of action plans with quantified targets to address those risks.
- Integration of actions to prepare for and respond to emergency situations.
- Evaluation of progress in reducing/preventing health issues/risks against targets.
- Internal inspections.
- Procedures to investigate work-related injuries, ill health, diseases and incidents.
- OHS training provided to employees and/or other relevant parties to raise awareness and reduce operational health & safety incidents.
- OHS criteria introduced in procurement and contractual requirements.

Post-Natal Leave

In Sigdo Koppers S.A., the rules of law govern the period of pre-natal and post-natal parental leave for both women and men. The company has no specific policy setting a period of additional or other type of leave.

No women or men were entitled to post-natal leave in 2024, so no one made use of this leave.

Talent attraction and retention

Having the best teams is key to attaining the strategic goals of Sigdo Koppers. That is why one of our main focuses is talent attraction and retention in all our subsidiaries.

Keeping people with great potential in the organization not only strengthens our competitiveness; it also ensures the continuity of our corporate culture and the knowledge capital that we have built over time.

Talent retention is crucial to preserving the productivity and efficiency of our operations as trained, committed professionals contribute to innovation, to the continuous improvement of processes and to the sustainability of the business.

To achieve this objective, the company encourages annual job climate surveys and performance evaluations and it is constantly monitoring the key officers of subsidiaries. This helps us identify opportunities for growth and development within the Group. We facilitate, by means of an active talent management, strategic moves among the different companies that is good for the professional development of individuals, motivates them to stay, and strengthens their commitment to the organization. This approach not only optimizes the performance of our subsidiaries but also helps the company to continue attracting and retaining the top talent, thereby ensuring its long-term success and growth.

Sigdo Koppers also has a People and Sustainability Committee comprised of the senior officers in the Human Resource areas of the Group's subsidiaries, coordinated by the parent company and headed by its Executive Chairman.

Each subsidiary of Sigdo Koppers carries out individual and/or team performance appraisal, such as Management by objectives, Multidimensional performance appraisal (e.g. 360 degree feedback), Team-based performance appraisal, and/or Agile conversations. Performance Appraisal Frequency: at least annually.



WE FACILITATE, BY MEANS OF AN ACTIVE TALENT MANAGEMENT, STRATEGIC MOVES AMONG THE DIFFERENT COMPANIES THAT IS GOOD FOR THE PROFESSIONAL DEVELOPMENT OF INDIVIDUALS



Total number of new employee hires in 2024:

1,904

Percentage of open positions filled by internal candidates:

35%

Average hiring cost/FTE:

US\$ **736**

In 2024,

81%

of employees reported the highest level of job satisfaction, based on a survey with

81%

participation across the organization.

2024 Employee Turnover Rate: **8.5% with a 100% data coverage**



Training and Banefits

More than received training,

} 12 thousand employees regardless of their type

SIGDO KOPPERS GROUP



It is fundamental to provide ongoing training to employees to have top teams capable of adapting to changes in technology and in regulations and to increasingly more dynamic scenarios.

Ongoing employee training is fundamental in order to guarantee that our teams continue to be pioneers in an ever more dynamic business setting. Trained employees are not only able to adapt quickly to technological advancements and regulatory changes but are also able to strengthen their ability to face new challenges and take advantage of the opportunities that may arise. Investing in a constant development of skills, both technical and soft, ensures that each member of the organization can contribute effectively to the company's strategic goals.

So, training not only improves productivity and efficiency but also fosters a culture of growth and continuous learning.

During 2024, Sigdo Koppers S.A. trained 22 employees, who accounted for 76% of all employees, for an investment of US\$48,000. Please note that since information is associated with the taxpayer identification number of Sigdo Koppers S.A., the investment in training represents less than 1% of annual income as income is comprised of the income from its equity interests in subsidiaries.

The main matters in which the employees of Sigdo Koppers S.A. received training in 2024 were: Cybersecurity, the Economic Crimes Law, the Tax Compliance Law, Law 21,643 on sexual and workplace harassment and workplace violence, and the English language.

Training Numbers	SIGDO KOPPERS PARENT COMPANY
Total amount of money allocated to education and professional development (in USD)	48,265
Total number of hours of training	1,646
% of employees trained as compared to the total number of employees	75.86%

SIGDO KOPPERS PARENT COMPANY	UPPERMANAGEMENT		MANAGEMENT		SUPERMSORS		ADMINISTRATIVE STAFF		OTHER PROFESSIONALS		TOTAL	
	Women	Men	Women	Men	Women	Men	Women	Men	Women	Men	Women	Men
Number of people with disabilities	0	1	4	2	2	0	0	2	8	3	14	8
Number of hour of training	0	87	445	148	162	0	0	2	621	182	1227	419
Average number of hours of training		86.5	111.3	74.0	80.8			1.0	77.6	60.7	87.6	52.3

US\$ 3 million was invested in training

SIGDO KOPPERS GROUP

770 hours of training

SIGDO KOPPERS GROUP

Average hours per FTE of training and development:

44

Average amount spent per FTE on training and development:

US\$ 173

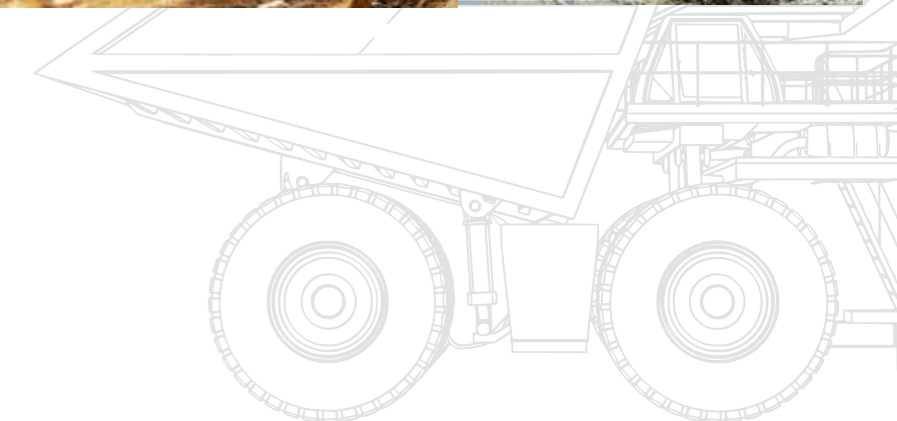

Employee Development Programs

Employee Support Programs

be nefits

Sigdo Koppers is committed to fostering the growth and development of its workforce through structured programs aimed at strengthening skills and preparing employees for future challenges.

These programs include:

Learning Methods Offered

The company provides a variety of internal and external learning opportunities, including:

- 01.** Coaching and mentorship to support individual growth and career progression
- 02.** Team-based learning and employee networks, such as - Employee Resource Groups, to encourage collaboration and peer development

Types of Development Programs

Sigdo Koppers offers a diverse range of programs tailored to meet the evolving needs of its employees, including:

- 03.** Leadership development programs to cultivate future leaders within the organization
- 04.** Cultural education initiatives to promote diversity, inclusion, and global awareness
- 05.** Digital transition programs to support employees in adapting to new technologies and digital tools.

Sigdo Koppers is committed to creating a supportive and inclusive work environment by offering a range of programs that promote well-being, work-life balance, and family support.

These include:

Employee Benefits

Access to sports and health initiatives that encourage physical and mental well-being

Work Conditions

Flexible working hours to accommodate personal and professional needs

Remote work arrangements to support productivity and balance

Family Benefits

Childcare support, including facilities or financial contributions

Breastfeeding and lactation benefits, with designated spaces and resources

Paid parental leave, including:

- Up to 18 weeks for the primary caregiver (e.g., mother)
- Up to 6 weeks for the non-primary caregiver (e.g., father)"



MUS\$	2021	2022	2023	2024
Total Revenue	3,096,889	3,943,436	4,006,223	3,780,665
Total Operating Expenses	2,042,266	2,630,781	2,631,944	2,671,174
Total employee-related expenses	797,150	905,737	1,021,319	806,691
Total Employees	22,731	23,052	22,223	17,443

CUSTOMERS

Sigdo Koppers S.A. provides, through its subsidiaries, integral solutions to customers throughout the mining and industry value chains. The companies have teams who aim to understand their needs, develop innovative products and services and stay in constant communication to respond quickly to their requests.

We endeavor to build long-term, transparent relationships with our customers. In doing so, we focus on providing innovative solutions, continuously performing work of excellence and meeting the agreed deadlines while always trying to exceed their expectations.

Our subsidiaries conduct regular satisfaction surveys to measure and improve our performance. Those surveys help us understand the needs and expectations of our customers. We also implement loyalty initiatives by providing an efficient after-sales service and having a profound understanding of each customer's processes. As a result, we can constantly offer added value and strengthen long-term relationships. This approach not only assures the continuing satisfaction of our customers but also fosters their loyalty and contributes to the sustained growth of our company.

No penalties were imposed on Sigdo Koppers S.A. in 2024 in relation to customers.

SUPPLIERS

We value our suppliers as strategic partners since their capacity to offer quality products and services by the agreed deadlines has a direct impact on our efficiency and competitiveness. So, we aim to guarantee the best terms of supply and establish long-term relationships, mainly for the supply of raw materials, construction materials, machinery and trucks.

We encourage open, transparent relationships that facilitate a fluid communication, quick problem-solving and ongoing collaboration to improve processes and results. By working together ethically and fairly, we guarantee that both parties grow and benefit. That strengthens our supply chain and contributes to long-term stability. This approach not only ensures the continuity of our operations but also promotes joint innovation, which creates a sound base from which market challenges can be faced.

To manage suppliers efficiently, Sigdo Koppers began implementing SAP Ariba in 2023 that will be in place in all subsidiaries in the world included in the project over a two-year horizon. The company has supplier evaluation and payment policies that guide the relationship with suppliers.

Payment to Suppliers

The Supplier Payment Policy of Sigdo Koppers S.A. provides clear guidelines on national and international suppliers. The goal is to guarantee an agile, transparent process, and a period of payment has been set of 30 days after the date of receipt of properly issued and undisputed invoices.

This policy classifies suppliers as critical and non-critical. Subsidiaries in Chile are allowed to be flexible in making this distinction based on the business or area of operation of each because of the variety of activities in which each engages. That is how we ensure that all payments are processed efficiently, according to the specific needs of each business segment.

The management of invoices of the suppliers of Sigdo Koppers S.A. is presented below.

Number of invoices paid:

the number of invoices paid during the year to suppliers in each of the ranges indicated.

SIGDO KOPPERS PARENT COMPANY			
Number of invoices	Foreign	National	Total
0 – 30 days	30	1,058	1,088
31 – 60 days	0	1	1
61 days or more	0	2	2

Total (US\$000's):

the sum of invoices paid during the year in each of the ranges indicated.

SIGDO KOPPERS PARENT COMPANY			
US\$000's	Foreign	National	Total
0 – 30 days	336.1	3,698.2	4,034.3
31 – 60 days	0	0	0
61 days or more	0	0	0

Number of Suppliers:

the number of suppliers who issued the invoices paid during the year in each of the ranges indicated.

SIGDO KOPPERS PARENT COMPANY			
Number of Suppliers	Foreign	National	Total
0 – 30 days	7	137	144
31 – 60 days	0	1	1
61 days or more	0	0	0

Please note that no interest had been recorded as of December 31, 2024 for a delay in paying invoices. And no agreements had been registered in the Register of Agreements with an Exceptional Period of Payment kept by the Ministry of Economy.

Supplier Evaluation

Subcontractors

Supplier evaluation is a key aspect in assuring the quality and sustainability of our supply chain. Sigdo Koppers S.A. has a Supplier Evaluation Policy that provides clear directives on the analysis of diverse factors before contracting a product or service. This process includes a review of the supplier's quality of corporate governance, their risk management system and other sustainability-related considerations. There is also a continuing analysis of supplier performance during the supply of goods and provision of services that means we can guarantee that the standards of quality, ethics and responsibility remain the same throughout our business relationship.

This evaluation not only helps improve continuously; it also strengthens the transparency and confidence in our supplier network, ensuring that we work with partners committed to the same standards and values as our company.

Based on the Group's defined strategy, ESG criteria began to be measured in 2024 as part of supplier evaluations, according to the goals defined by each subsidiary.

Sigdo Koppers has a Subcontracting Policy that stipulates how to relate with the companies providing services. Subcontracting rules are applicable to those companies and to their entire value chain. These guidelines determine the relevant aspects of the relationship with contractors and subcontractors and the general human resources policies enforceable in respect of their employees.

The company also requires, in contracting service providers, compliance by them, as concerns employees, with labor and social security laws and regulations. Sigdo Koppers takes purposeful action to prevent work accidents and occupational illnesses that may impact its own employees or persons providing services to its operations even though they are employed by another company.

The areas in charge of administrating subcontracts in the Group's subsidiaries consider this policy in the terms and conditions of tenders and service contracts and in selecting candidates. Those areas also require that prior to making any payment to such providers, it is confirmed that they are in compliance with the health insurance, retirement and social security payments to be made on behalf of their own employees.



Ensuring Effective Implementation of Supplier ESG Programs

Sigdo Koppers has established clear measures to ensure that its Supplier ESG Programs are implemented effectively and consistently across its supply chain. These measures include:

- **Executive Oversight:** Senior management is directly responsible for overseeing the implementation and monitoring of supplier ESG performance.
- **Alignment of Purchasing Practices:** The company reviews its purchasing practices to ensure they are consistent with the Supplier Code of Conduct, avoiding any misalignment with ESG requirements.
- **Minimum ESG Standards:** Suppliers who fail to meet the minimum ESG standards within a defined time frame are excluded from contracting opportunities.
- **ESG-Based Supplier Preference:** Preference is given to suppliers who demonstrate stronger ESG performance in selection and contract award processes.
- **Internal Training:** Training is provided to the company's buyers and relevant internal stakeholders to ensure they understand their roles and responsibilities within the supplier ESG program.

Screening of Significant Suppliers

Sigdo Koppers evaluates its significant suppliers based on a combination of key criteria and risk-based methodology to ensure alignment with our ESG standards and business priorities.

- **Screening Criteria:** Environmental performance
Social responsibility
Governance practices
Strategic business relevance
- **Screening Methodology:** Country-specific risk analysis
Sector-specific risk assessment
Commodity-specific risk evaluation

Assessment and Development of Significant Suppliers

At Sigdo Koppers, we take a proactive approach to evaluating and strengthening our supply chain. Our supplier assessment and development practices include the following:

- **Supplier Assessment:** Structured desk assessments with systematic verification of supporting evidence

On-site assessments conducted by purchasing company staff or external consultants (second-party audits)

Supplier corrective action/improvement plans
- **Supplier Development:** Sharing information and providing training on our Supplier ESG Program, including processes and requirements

Offering access to ESG performance benchmarks to help suppliers compare themselves with industry peers

Providing support—either remotely or on-site—for the implementation of corrective and improvement actions

Delivering in-depth technical assistance to help suppliers enhance their capabilities and overall ESG performance

INVESTORS AND FINANCIAL ENTITIES

Investors and financial entities play a fundamental role for the company as they provide the capital needed to finance its operations and growth.

In this respect, we are focused on maximizing the return on investments, on continuously creating value and on maintaining a long-term vision. This focus not only ensures the confidence and backing of our investors but also allows the company to continue growing, innovating and attaining its financial goals while always staying true to the commitment of creating value for all parties involved.

Sigdo Koppers has an Investor Relations area in charge of providing information and answering questions by investors about the main risks, financial, economic or legal situation and publicly known transactions of the entity. This unit can be contacted from the Sigdo Koppers website.

In line with the above, the company also has a Manual on Handling Information of Interest to the Market that indicates: the owners; the type of information on Sigdo Koppers as an entity registered in the Securities Register; the key information disclosure procedure; the handling of privileged information; the disclosure of information of interest to the market; the obligation to report certain transactions of shares and securities by directors, managers, senior officers and related persons; continuous information; privileged information; the prohibition to trade the company's securities in the cases listed; the means of protecting confidential information; training; compliance with the manual and penalties; and period of effectiveness.

The shareholders register of Sigdo Koppers is administrated by Sercor.

During 2024, the company took the following actions to maintain a close and transparent relationship with market analysts, investors and shareholders:

- 01. In-person presentation of quarterly results for 4Q23, 1Q24, 2Q24 and 3Q24.**
- 02. More than 160 meetings with investors, brokers, general fund managers, banks and risk rating agencies.**
- 03. Attendance of two conferences: the LarrainVial Andean Conference (Chile) and the Credicorp Andean Conference (Peru).**
- 04. Launching of Corporate Broking during the Site Visit with investors to the plants and facilities of Enaex and to Puerto Abierto of PVSA in Mejillones, Chile.**

AUTHORITIES AND REGULATORS

Sigdo Koppers maintains a transparent relationship with authorities and regulators in which it complies with regulations. This demonstrates our commitment to the best corporate governance practices. This stakeholder is highly important because they are actors key to the company operating as it should and maintaining its reputation.

We strive to do business according to law to protect the interests of investors, shareholders and the market in general, and our ongoing interaction with authorities and regulators reinforces the trust of the public and of investors, which is crucial to the financial stability and sustained growth of the company.

COMMUNITIES AND SOCIETY

We are committed to playing an active role in creating value for local communities and to ensuring that our operations not only generate economic benefits but also contribute to the social progress and wellbeing of individuals.

100%
of companies have a community engagement strategy and program

SIGDO KOPPERS GROUP



WE STRIVE TO ESTABLISH RELATIONSHIPS OF TRUST AND COLLABORATION WITH COMMUNITIES AND TO CONTRIBUTE TO THE LONG-TERM DEVELOPMENT OF THE REGIONS WHERE WE ARE PRESENT.



We respect local customs and traditions in all our activities and we adapt to the realities of each region. We also aim to minimize the impact of our operations on the environment by implementing responsible practices that promote sustainability and care for the environment.

So, we strive to establish relationships of trust and collaboration with communities and to contribute to the long-term development of the regions where we are present.

Each of the subsidiaries of Sigdo Koppers implements initiatives according to the interests and needs of this stakeholder. However, on a corporate level, we channel this contribution through vocational education, an area where we have sought to improve the quality of life of people and aid in their social progress. We also promote inclusion and equity in this area, which are cross-cutting pillars of the education we offer through our subsidiary, SK Capacitación S.A., and through Fundación Educacional Chile Dual.

Sigdo Koppers fosters creating alliances with civic organizations. Subsidiaries are conducting diverse research programs for the development of new products with international academic institutions and universities. The company has also signed the U.N. Global Compact.

We are, in addition, active participants in trade associations. This keeps us informed of the trends and changes in the sector, helps us share knowledge and experience with other key actors, and collaborate in creating solutions to common challenges in our industry. Either the parent company or subsidiaries are members of, depending on their business, the Manufacturing Development Society (SOFOFA in Spanish); the Association of Metallurgical and Metal Mechanics Industries (ASIMET in Spanish); the Chilean Chamber of Construction (CCHC); the Chilean Institute of Rational Business Administration (ICARE in Spanish); the Production and Trade Confederation (CPC in Spanish); the Trade Association of Industrial Chemists of Chile (ASIQUM in Spanish); and the Association of Industrial Mining Suppliers (APRIMIN in Spanish), among others..

0
stoppages because of community

SIGDO KOPPERS GROUP

US\$ **3.4**

million invested in community programs

SIGDO KOPPERS GROUP

OUTSTANDING INITIATIVES

01. Fundación Educacional Chile Dual

The Chile Dual Foundation was created by Sigdo Koppers to link students at Vocational Schools to the production sector and thus improve their educational and career paths.

Impact of Fundación Chile Dual	2022	2023	2024
Students	4,049	5,800	6,900
Vocational Schools	286	214	139
Teachers		1,142	359

02. Youth Employability

Enaex developed a total of 39 social and shared-value projects in 2024, impacting more than 16,300 people.

One of the main focuses is on the programs that have an impact on education and youth employability. The goal is for students participating in the programs to join the company after completing their education, thereby creating value for the community and for Enaex because it can employ youths who already understand the culture and the business. Special interest has been placed on incorporating women to these programs. 8 education programs were implemented in the year in Chile, focused on 11 th and 12 th graders, involving 369 students in Mejillones, Calama and Santiago.

Also noteworthy are the Blasting Specialist program being held with Minera Collahuasi in which 223 students participated, as well as the Chemical Plant Operator program at the Rio Loa Plant in Calama. The curriculum for this latter program has been approved by the Ministry of Education and is supported by AIEP (Academy of Languages and Professional Studies) of Andres Bello University.

03. Sargent Aldea Vocational School

For the past 26 years, Puerto Ventanas has been implementing a dual education program with the Sargent Aldea Vocational School, which Fundación Chile Dual joined in 2024. 11 th - and 12 th -grade students in the municipality of Puchuncaví did their internships in the company.

Today, PVSA has among its employees individuals who were employed under this strategy, which represents the commitment to education in the municipality.

04. Train-Ing (Trenzando)

In 2024, Fepasa supported the implementation of the Train-Ing (Trenzando) program, a territorial cooperation platform of Fundación Acto (Act Foundation), based on reusing the railroad system. It strives to create greater opportunities for the development of non- metropolitan localities by facilitating access to, and the exchange of, know-how and technology, in addition to an appreciation of local heritage. A traveling cultural center travels by rail, offering spaces and tools to engage in activities designed in conjunction with the representatives of each community.

Trenzando made its first "Train-Ing to the South" journey during which it visited the Rucapequén, Yumbel and San Rosendo Stations, offering a program of theater, film, music, typical cuisine and communications.

05. Integral Educational Robotics and Neuroscience Project

Sigdo Koppers Ingeniería y Construcción Group (SKIC Group) supported the implementation of the Integral Educational Robotics and Neuroscience Project (RIEN) in 2024 at the Pedro Aguirre Cerda School in Conchalí, to which it has been providing aid for the past four years and which is located near its facilities.

The purpose of this project is to measure the impact of educational robotics and thereby contribute to students' formation.

06. SKC Impulsa

SKC Impulsa is a dual education program created by SKC in an alliance with institutions like INACAP and vocational schools. Its goal is to reduce the gaps in vocational education.

It is a public-private alliance among the Kiri Chile Foundation, the Mustakis Foundation, the Municipality of Conchalí and SKIC Group.

It provided more than 2,600 hours of training according to curricula differentiated into areas like automobile mechanics, focusing on students in the 11 th and 12 th grades. This initiative is additional to the ones already implemented under our Dual Education Program that has been of benefit to more than 430 youths since 2015, combining theory and practice to foster employability, further their access to higher education, and connect education to the working world.

39

social and shared-value projects impacting more than

16,300

people

ENVIRONMENTAL PERFORMANCE

SIGDO KOPPERS REMAINS FIRMLY COMMITTED TO ENVIRONMENTAL SUSTAINABILITY. IT ENCOURAGES A CONTINUOUS IMPROVEMENT OF OUR PERFORMANCE AND PRIORITIZES THE SUSTAINABLE MANAGEMENT OF RESOURCES.

Our strategy in this area is based on three basic principles that guide the company's commitment to sustainable development and to the mitigation of environmental impacts:

01.

The protection of the environment by preventing environmental impacts.



02.

The environmental responsibility in the different areas of its performance.



03.

The adoption of, and compliance with, applicable environmental regulations and environmental



COMMITMENTS



Integral Regulatory Compliance



Management of Environmental Risks and Control of Environmental Impacts



Climate Change Management



Circular Economy



Efficient Use of Water and Energy Resources



Care of the Biodiversity

Policy

We have a Climate Change and Environmental Management Policy that sets down a common framework for our subsidiaries around the world and guides our commitment to sustainable development and to the control of environmental aspects.

Governance

Sigdo Koppers has set up a corporate Environment Committee comprised of the subsidiaries in the SK Group. This committee analyzes and implements new regulatory or market requirements, new corporate standards and guidelines and good practices, and it provides training to reinforce knowledge.

Certifications

Our subsidiaries hold international certifications like ISO 14001 for environmental management and ISO 50001 for energy efficiency. This means that we have controlled, standardized processes in each of our operations.

Reportability

Environmental performance is monitored through corporate environmental indicators that are received regularly from the Group's subsidiaries and are a fundamental part of the company's reporting to society and to the financial market.





- THE HIGHEST DECISION-MAKING BODY THAT ENDORSES AND/OR OVERSEES
THIS POLICY IS THE BOARD OF DIRECTORS.

The frequency with which climate-related issues are scheduled agenda items is at least annually.

Scope of the policy:
Own Operations

Sigdo Koppers commits to integrating the TCFD framework in 2027

The Sigdo Koppers Environmental Management and Climate Change Policy reflects our commitment to sustainability through the following key aspects:

- 01.** Establishing clear accountability to ensure effective implementation of the policy
- 02.** Driving continuous improvement in our environmental performance
- 03.** Setting specific goals and objectives to reduce our environmental impact
- 04.** Providing training to help employees understand how our operations affect the environment
- 05.** And promoting a culture of environmental responsibility across the organization

Climate Risk Management

Sigdo Koppers has established a documented climate risk management process that is fully integrated into its company-wide, multi-disciplinary Enterprise Risk Management (ERM) system. This approach ensures that climate-related risks and opportunities are evaluated alongside all other types of strategic, operational, and financial risks.



Types of Climate-Related Risks Assessed

The company's risk assessment covers a broad spectrum of climate-related risks, including:

- Current regulatory requirements
- Emerging regulatory changes
- Technology transitions and risks
- Legal and compliance exposure
- Market-related risks
- Reputational impact
- Acute physical risks (e.g., extreme weather events)
- Chronic physical risks (e.g., long-term environmental changes)

Scope of the Assessment

- **Value Chain Coverage:**
The assessment currently includes Sigdo Koppers' own operations
- **Time Horizons Considered:**
Short-term impacts
Medium-term projections

ENVIRONMENTAL MANAGEMENT

In 2024, we continued progressing in the global implementation of ISO 14001 on Environmental Management and of ISO 50001 on energy management at production plants where there is a high energy consumption.

Our environmental management model is based on five priority aspects:

- 01. air** These aspects are monitored as part of environmental management and regulatory compliance to facilitate controlled, standardized processes at each of our operations.
- 02. water**
- 03. energy**
- 04. waste** The Sigdo Koppers Group also works continuously on environmental risk management. It has developed specific plans to mitigate the potential impacts of its operations on local ecosystems. Those plans include monitoring and a continuous evaluation of regulatory compliance.
- 05. biodiversity**

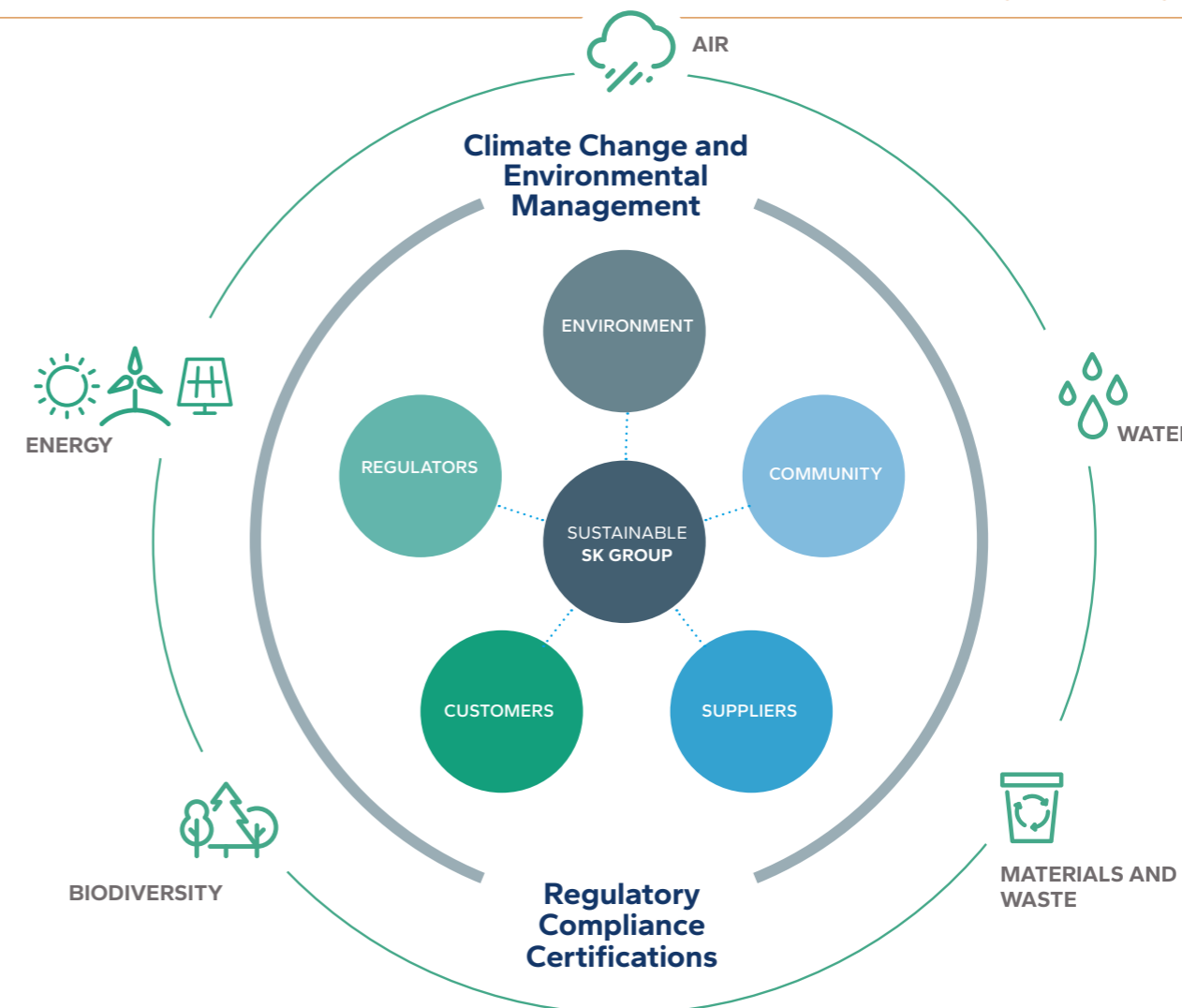

Air

Implement strategies that promote initiatives to reduce greenhouse gas emissions and foster the use of renewable energy, cleaner fuels and energy efficiency.

Water and Energy

Promote a progressive increase in the efficient use of the water and energy used in the operations of the Sigdo Koppers Group.

Drive the implementation of energy management systems as a tool for the continuous improvement of energy performance.

Materials and Waste

Advance circularity strategies based on optimizing the use of resources, the consumption of raw materials and inputs and on reducing and repurposing waste.

Biodiversity

Further the conservation of biodiversity in all companies and in their operational settings.

Implement good practices of protecting ecosystems according to their nature, the impact of activities and governing laws.

SK's Environmental Management System is verified according to international standards — ISO 14001 and ISO 50001 — and coverage is

90%
coverage.

EMISSIONS MANAGEMENT

The subsidiaries in the Sigdo Koppers Group have set their 2030 climate change goals internally based on the nature of their business and their environmental considerations.

We must emphasize the expansion of the coverage of our Corporate Carbon Footprint (SK Group) to 90% of subsidiaries.



AN INCREASE IN THE COVERAGE OF OUR CORPORATE CARBON FOOTPRINT TO

91%



Climate Change and Greenhouse Gases

(SASB - EM-MM-110a.2)

Quantification of Greenhouse Gases

(SASB - EM-MM-110a.1)

SUBSIDIARIES

		Enaex	Magotteaux Group	PVSA	Fepasa	SKIC Group	SKC
Scope 1: Direct Emissions	ton CO2-e	695,000	69,400	627	2,010	21,282	1,603
Scope 2: Energy Emissions	ton CO2-e	10,000	262,113	1,265	228	728	471
Scope 3: Indirect Emissions	ton CO2-e	893,000	1,169,295	181,707	12,052	205,505	6,122
Coverage	%	84%	100%	100%	100%	100%	84%

SIGDO KOPPERS GROUP

		2022	2023	2024
Scope 1: Direct Emissions	ton CO2-e	297,900	358,404	871,345
Scope 2: Energy Emissions	ton CO2-e	141,607	377,071	316,549
Scope 3: Indirect Emissions	ton CO2-e	2,234,882	6,126,521	2,578,152

Notes:

- The greenhouse gas emissions reported were in the process of external assurance at the close of this report and may vary.
- The final assured figures will be posted on the Sigdo Koppers S.A. website.
- The Scope 1 emissions rose significantly because of an operating situation in Enaex. It had to work for 4 months without a secondary catalyst in PANNA4 at the Prillex Plant, which resulted in less abatement than would be expected in a normal year of operation.

In line with our climate change and environmental strategy, in 2024 we quantified the greenhouse gas emissions (GHG) of all our subsidiaries in Scopes 1, 2 and 3, which were externally assured according to the GHG Protocol and ISO-14064.

Air Quality

(SASB - EM-MM-120a.1)

Stationary Source Air Emissions

SUBSIDIARIES

		Enaex	Magotteaux Group	SKC
PM10	ton	10	130	4
SOx	ton	22	23	-
NOx	ton	57	19	-
COV	ton	1	85	-
CO	ton	10	32	-
Coverage	%	100	100	100

SIGDO KOPPERS GROUP

		2020	2021	2022	2023	2024
PM10	ton	161	135	110	104	142
SOx	ton	8	8	7	33	54
NOx	ton	130	23	23	25	93
COV	ton	-	-	85	80	86
CO	ton	-	-	24	21	42

Note:

- The operations of the subsidiaries in the Sigdo Koppers Group do not emit mercury (Hg) or lead (Pb), so no measurement of these pollutants is reported.

Scope 3 Category

	Emissions in the reporting year (Metric tons CO2e)
1. Purchased Goods and Services	1.838.845
2. Capital Goods	15.310
3. Fuel-and-energy-related-activities (nos included in Scope 1 or 2)	101.275
4. Upstream transportation and distribution	103.163
5. Waste generated in operations	54.389
6. Business travel	17.804
7. Employee commuting	7.653
8. Upstream leased assets	5.898
9. Downstream transportation and distribution	431.084
10. Processing of sold products	-
11. Use of sold products	9.518
12. End of life treatment of sold products	1.804
13. Downstream leased assets	405
14. Franchises	-
15. Investments	-

Enaex, a leading company in blasting products and services, generates its revenue from the sale of explosives, products containing substances classified as hazardous by regulatory authorities.

In 2024, Enaex's consolidated revenues represented approximately 50% of Sigdo Koppers' consolidated revenues. All of Sigdo Koppers' consolidated revenues are subject to a risk assessment for human health and the environment.

Note: The environmental data reported by Enaex, for the year 2024, has been externally verified by an independent third party to ensure its accuracy, traceability, and consistency with the applicable reporting standards.

Link: <https://www.enaex.com/cl/content/uploads/sites/2/2023/07/Carta-de-Verificacion-Indicadores-v0-EN-2024.pdf>



There is no dedicated board-level committee responsible for the oversight of climate-related issues. However, such issues are presented to the Board of Directors and included on the agenda at least once a year.

Further, there is a management position and committee responsible for climate-related issues: Environmental Committee headed by the Corporate Environmental Management Manager.

Note: The Greenhouse Gas (GHG) emissions reported for the year 2024 have been externally verified by independent third parties to ensure accuracy, transparency, and compliance with international reporting standards, including ISO 14064 and the GHG Protocol.

The verification results are publicly available on our corporate website.

https://www.sigdokoppers.cl/content/uploads/ghg_certificates-2024.pdf

ENERGY MANAGEMENT (SASB - EM-MM-130a.1)

To encourage a progressive increase in the efficient use of energy resources utilized in the operations of the Sigdo Koppers Group, the decision was made to implement energy management systems as one way of continuously improving the energy performance of operations that are large-scale power consumers. We also promote acquiring energy-efficient products and services.

In this area, Sigdo Koppers is gradually moving towards a sustainable energy matrix.

In 2024, the coverage of the ISO 50001 certification of energy management at high-consuming plants was broadened. 35% of production and similar operations have their

energy management systems certified and are focused on reducing energy consumption and on continuous improvement.

Of note are diverse renewable energy projects put into place at the operations of Magotteaux, such as solar panels installed in India and a solar farm in Thailand. International Renewable Energy Certificates (IRECs) were also purchased for the plants of Enaex in Chile and Peru and the plants of Magotteaux in China, India and South Africa.

The initiatives taken have helped make advancements in reducing Scope 2 GHGs and in increasing the percentage of renewable energy in our energy matrix, which was at 34% at the end of 2024.

The Sigdo Koppers Energy Management Program is committed to improving energy efficiency and promoting sustainable practices through the following actions:

- Performing energy audits to uncover opportunities for better energy performance
- Setting clear, measurable targets to achieve energy savings
- Implementing actions to reduce overall energy consumption
- Regularly evaluating progress to ensure continuous improvement
- Promoting the use of clean or renewable energy sources
- Investing in innovation and research to drive long-term reductions in energy use
- Awareness programs and training provided to employees to encourage energy-efficient behaviors and practices

35% **34%**

of production and similar operations have their energy management systems certified.

of the energy used in operations comes from renewable sources.

Note: The environmental data reported by Enaex, for the year 2024, has been externally verified by an independent third party to ensure its accuracy, traceability, and consistency with the applicable reporting standards.

Link: <https://www.enaex.com/cl/content/uploads/sites/2/2023/07/Carta-de-Verificacion-Indicadores-v0-EN-2024.pdf>

Energy Consumption Indicators

SUBSIDIARIES		Enaex	Magotteaux Group	PVSA	Fepasa	SKIC Group	SK Godelius	SKC
Power consumption (from the grid)	MWh	24,393	556,964	74	760	1,738	41	1,436
Renewable energy	MWh	235,004	58,363	6,179	-	191	-	1,255
Total Electricity	MWh	259,397	615,327	6,253	760	1,929	41	2,691
Total Electricity	GJ	933,827	2,215,178	22,511	2,736	6,946	148	9,689
Coverage		100%	100%	100%	100%	100%	100%	100%

SIGDO KOPPERS GROUP GLOBALLY		2020	2021	2022	2023	2024
Power consumption (from the grid)	MWh	474,454	550,013	555,614	626,640	585,407
Renewable energy	MWh	2,661	4,195	96,100	261,890	300,992
Total Electricity	MWh	477,115	554,208	651,714	888,530	886,398
Total Electricity	GJ	1,717,614	1,995,149	2,347,566	3,198,708	3,191,135
% Renewable Energy	%	1%	1%	15%	29%	34%

Fuel Consumption

SUBSIDIARIES		Enaex	Magotteaux Group	PVSA	Fepasa	SKIC Group	SK Godelius	SKC
LPG	kg	1,798,913	6,034,264	3,391	615	16,328	-	39,227
NG/LNG	m3	703,815	18,466,369	-	-	4,018	-	-
Diesel Fuel	L	4,559,373	602,656	232,335	11,830,813	6,523,978	2,525	581,063
Gasoline	L	339,793	39,692	11,495	20,927	23,143	882	26,976
Coverage		100%	100%	100%	100%	100%	100%	100%

SIGDO KOPPERS GROUP GLOBALLY		2020	2021	2022	2023	2024
LPG	Kg	6,827,934	8,632,068	7,796,876	7,657,442	7,892,737
NG/LNG	m3	12,764,458	14,099,514	11,730,067	17,439,299	19,174,202
Diesel Fuel	L	29,916,583	26,180,504	23,246,186	23,589,076	24,332,743
Gasoline	L	917,599	653,692	543,458	743,907	462,909

Consolidated Non-Renewable

SIGDO KOPPERS GROUP		2020	2021	2022	2023	2024
Electricity	MWh	474,454	550,012	555,614	626,640	585,407
LPG	MWh	83,984	106,174	95,902	94,187	97,081
NG	MWh	122,028	134,791	112,139	166,720	183,305
Diesel	MWh	318,612	278,822	247,572	251,224	259,144
Gasoline	MWh	8,442	6,014	5,000	6,844	4,259
Total Non-Renewable Energy	MWh	1,007,519	1,075,814	1,016,227	1,145,614	1,129,195



Note: The environmental data reported by Enaex, for the year 2024, has been externally verified by an independent third party to ensure its accuracy, traceability, and consistency with the applicable reporting standards.

Link: <https://www.enaex.com/cl/content/uploads/sites/2/2023/07/Carta-de-Verificacion-Indicadores-v0-EN-2024.pdf>

91

is the total for the operations of Sigdo Koppers subsidiaries*

WATER MANAGEMENT

The SK Water Efficiency Management Program focuses on making smarter and more responsible use of water through the following actions:

Assessing how water is currently used to spot opportunities for saving and improving efficiency

Taking concrete steps to reduce overall water consumption

Implementing measures to improve the quality of wastewater before it's discharged

Setting clear, measurable targets to cut water usage

Promoting the reuse of water through recycling practices

Raising awareness and training employees to actively support water efficiency efforts

Water Stress

(SASB - EM-MM-140a.1)

The Sigdo Koppers Group identified all its industrial and production activities around the world to determine whether they are located in moderate, high or extremely high water-stressed zones.

The review was made using the Aqueduct tool of the Water Risk Atlas of the World Resource Institute (WRI).

	Operations in Water-Stressed Zones		
	High (40-80%)	Extremely High (>80%)	Total (High + Extremely High)
Number	7	34	41
%	8%	37%	45%

Coverage 100%

(* The operations of the Sigdo Koppers Group (subsidiaries) means activities under the control of Sigdo Koppers S.A.

Operations Map: Production plants, industrial projects of SKIC Group, industrial facilities and services.

No salesrooms or purely administrative operations are included.

Water Consumption, Withdrawal and Discharge

(SASB - EM-MM-140a.1)

SUBSIDIARIES

		Enaex	Magotteaux Group	PVSA	Fepasa	SKIC Group	SKC
Consumption of potable water from public water system (A)	Mm3	147	464	30	20	26	40
Water withdrawal from groundwater tables (B)	Mm3	238	127	-	-	86	5
Water withdrawal from surface water (C)	Mm3	315	11	-	-	33	-
Discharges*(D)	Mm3	57	0	-	-	-	-
Total Fresh Water Consumption (A+B+C-D)	Mm3	643	602	30	20	145	45
Total seawater withdrawal	Mm3	46	-	-	-	-	-
Coverage		100%	100%	100%	100%	100%	100%

* Discharges: Water returned to the extraction source with a quality similar to or better than that of the raw water withdrawn (bodies of water).

SIGDO KOPPERS GROUP GLOBALLY

		2020	2021	2022	2023	2024
Consumption of potable water from public water system (A)	Mm3	416	525	526	704	728
Water withdrawal from groundwater tables (B)	Mm3	290	417	289	524	456
Water withdrawal from surface water (C)	Mm3	143	36	50	349	359
Discharges*(D)	Mm3	-	-	67	49	57
Total Fresh Water Consumption (A+B+C-D)	Mm3	850	977	799	1,526	1,486
Seawater	Mm3	-	-	32	43	46

* Discharges: Water returned to the extraction source with a quality similar to or better than that of the raw water withdrawn (bodies of water).

% of Sigdo Koppers operations in water-stressed zones

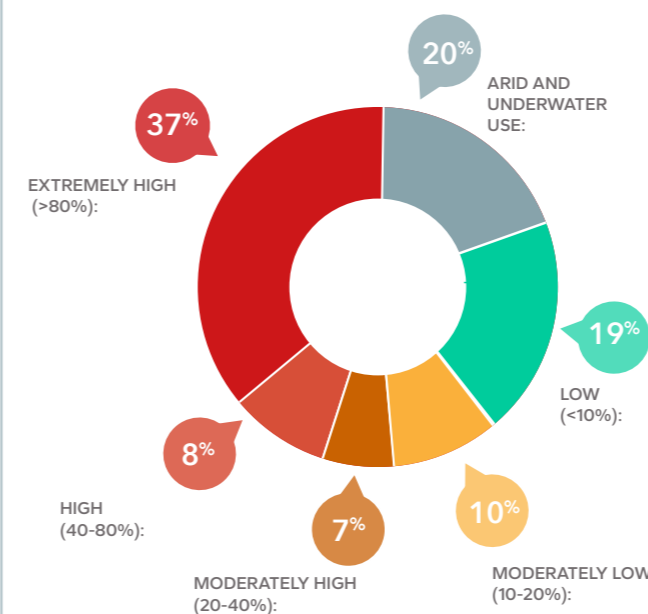

% Of Operations Of Sigdo Koppers Subsidiaries In High And Extremely High Water-Stressed Zones

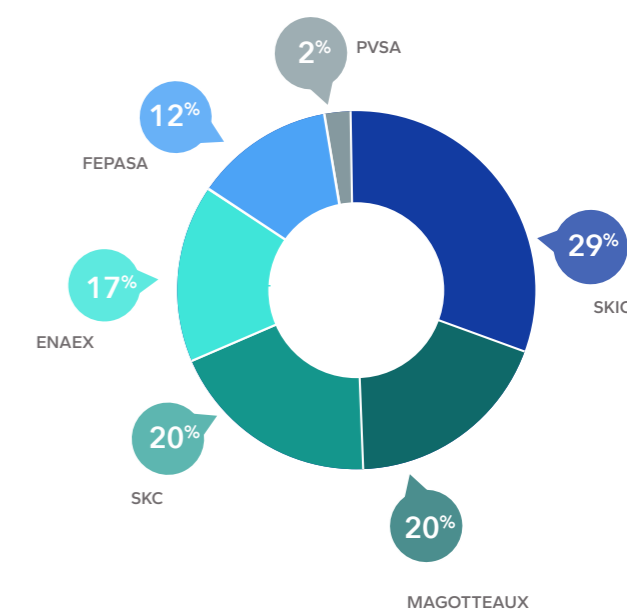

BIODIVERSITY

(SASB - EM-MM-160a.1)

Sigdo Koppers is aware that biodiversity is essential in caring for the environment. So, it decided to set a separate goal of promoting and encouraging all companies in the Group to implement good practices of biodiversity and ecosystem protection based on the nature of their operations, the impact of their activities and governing regulations.

Active operations and the sites in or near protected areas are mapped each year to maintain an ongoing environmental control of the operations involved and to comply with regulations on the Biodiversity component.

94

3 additional areas of interest have been added to the 91 operations of the SK Group that are in the cargo transport route of Fepasa.

Total number of operations of Sigdo Koppers subsidiaries

21%

of operations are in or near protected areas

	Inside a protected area	Near a protected area (5 km)
Number of operations of Sigdo Koppers subsidiaries	4	16

The companies in the Sigdo Koppers Group work within an ISO 14001 Environment Management framework for the purpose of controlling and preventing any material impact on the environment. They have also implanted a common standard to identify sites in a state of conservation and/or declared protected zones in a radius of 5 kilometers near plants and operations. For this reason, a global map has been prepared to identify protected areas or potential habitats of endangered species near the companies' facilities.

This facilitates taking preventive and environmental control actions in regard to biodiversity.

El levantamiento se realiza mediante el uso de herramientas de información geográfica, utilizando fuentes bibliográficas de los gobiernos locales de cada filial, en conjunto con los líderes ambientales de las plantas y operaciones.

Como resultado de este análisis, se concluye que 20 operaciones a nivel global se encuentran cercanas a un área protegida.

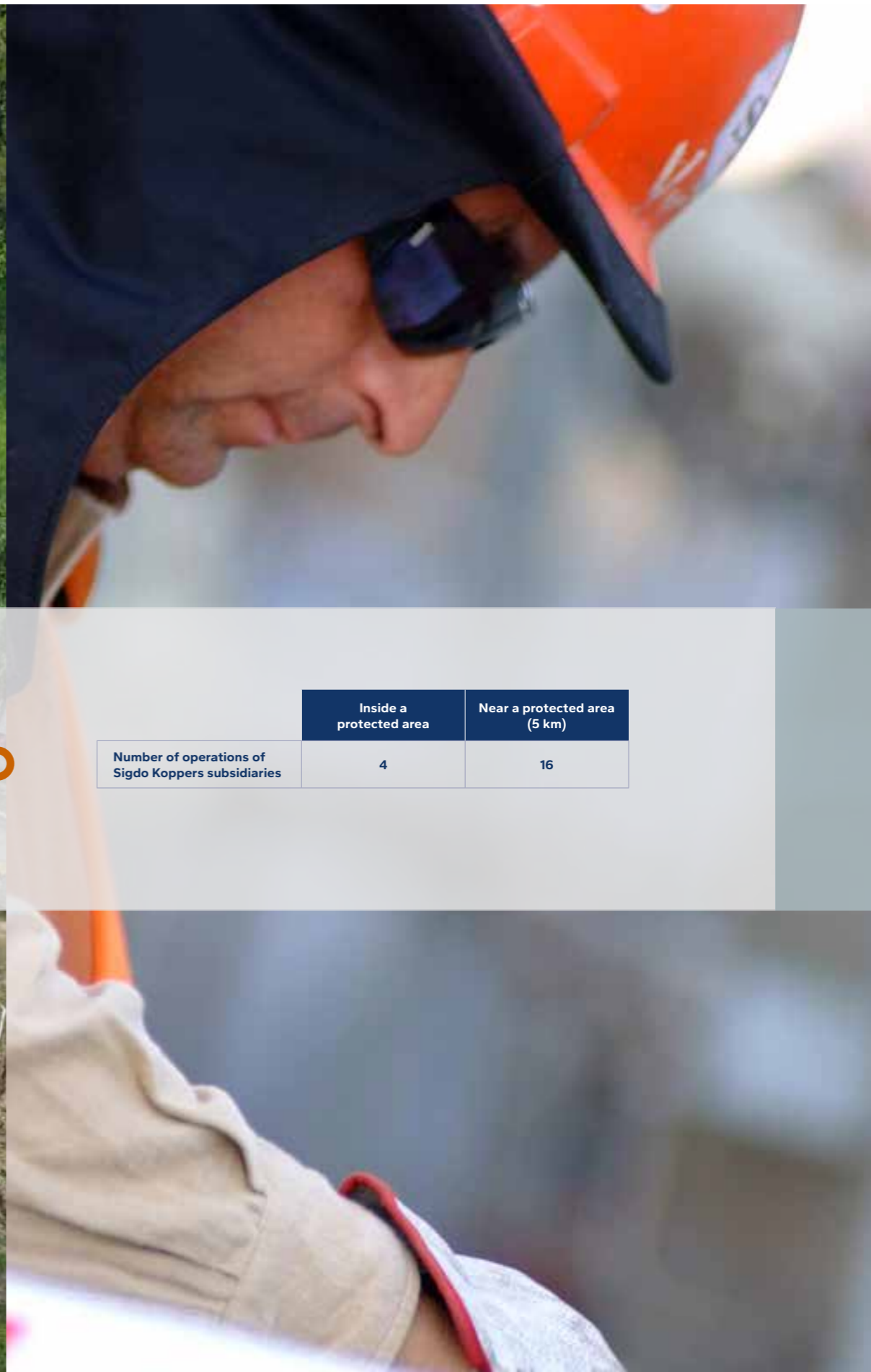

Biodiversity Risk Assessment

Sigdo Koppers has completed a biodiversity risk assessment as part of its commitment to environmental stewardship and sustainable operations. The process is transparent, methodologically robust, and integrated into the company's broader risk management framework.

Assessment Scope:
Own Operations: Direct operational sites are included in the scope of analysis.
Adjacent Areas: Surrounding environments near operational sites are also considered, reflecting a broader ecosystem perspective

Biodiversity Protection

Through its Environmental Management and Climate Change Policy, Sigdo Koppers commits to and encourages all SK Group companies to implement good practices in their operations that protect biodiversity and ecosystems, in accordance with their nature, commercial impact, and applicable regulations.

This policy was approved by the Sigdo Koppers Board of Directors.

Sigdo Koppers is committed on no-deforestation

Extent of the commitment:
End all deforestation (no gross deforestation)

Target year
2024

Scope of commitment:
own operations

Highest endorsing decision-making body:
Executive Management

Process Overview

- 01. Public Disclosure:** The company publicly reports the steps involved in its biodiversity risk assessment.
- 02. Location-Specific Analysis:** The assessment applies a site-specific approach, recognizing the unique ecological context of each operational area.
- 03. Recognized Methodologies:** The process is based on established methodologies and frameworks relevant to biodiversity risk assessment.
- 04. ERM Integration:** Biodiversity risks are evaluated within the company's multi-disciplinary, company-wide Enterprise Risk Management (ERM) system.
- 05. Impact-Oriented:** The assessment explicitly considers biodiversity risks related to the environmental impact of operations.



WASTE

SIGDO KOPPERS IS COMMITTED TO REDUCING HAZARDOUS SUBSTANCES IN ITS PRODUCTS THAT CONTAIN HAZARDOUS SUBSTANCES.



21%

of the wastewater generated by our operations was sent to recycling during the year

26%

percentage of products sold last year that can be reused or recycled (Sigdo Koppers consolidated sales in US\$)



Hazardous and Non-Hazardous Waste Management

(SASB - EM-MM-150a.4)

The Sigdo Koppers Group has focused on complying strictly with the rules and regulations on managing hazardous and non-hazardous waste and on encouraging the adoption of techniques that optimize the utilization of resources and reduce the consumption of raw materials.

It also fosters opportunities that entail the reuse of waste and materials that have completed their useful life to give them a new use that will extend that life.

SUBSIDIARIES

		Enaex	Magotteaux Group	PVSA	Fepasa	SKIC Group	SKC
Hazardous waste sent to final disposal	Ton	1,491	5,525	21	189	177	570
Recycled/reused hazardous waste	Ton	880	3,758	-	4	-	103
Non-hazardous waste sent to final disposal	Ton	1,182	56,335	655	47	3,266	209
Recycled/reused non-hazardous waste	Ton	1,678	57,400	26	939	3,479	325
Total Waste Generated	Ton	5,231	123,018	702	1,179	6,922	1,207
Coverage		100%	100%	100%	100%	100%	100%

SIGDO KOPPERS GROUP GLOBALLY

		2020	2021	2022	2023	2024
Hazardous waste sent to final disposal	Ton	4,927	4,927	5,086	5,555	7,972
Non-hazardous waste sent to final disposal	Ton	74,223	116,143	42,962	59,870	61,694
Recycled/reused waste	Ton	82,016	65,431	63,679	72,655	68,591
Total Waste Generated	Ton	161,166	186,501	111,727	138,080	138,257

SIGDO KOPPERS GROUP GLOBALLY

		2020	2021	2022	2023	2024
Recycling	%	51%	35%	57%	53%	50%

Waste Distribution

Total Waste

SIGDO KOPPERS GROUP

		2020	2021	2022	2023	2024
Total waste recycled/ reused	Ton	82016	65431	63679	72655	63846
Total waste disposed	Ton	74223	116143	42962	59870	61694
- Waste landfilled	Ton	74223	116143	42962	49798	48835
- Waste incinerated with energy recovery	Ton				117	264
- Waste incinerated without energy recovery	Ton				0	0
- Waste otherwise disposed	Ton				9955	12595
Data coverage	%	100	95	100	100	100

Hazardous Waste

SIGDO KOPPERS GROUP

		2020	2021	2022	2023	2024
Total waste recycled/ reused	Ton				9,121	4,744
Total waste disposed	Ton	5,111	4,566	5,086	5,555	7,972
- Hazardous waste landfilled	Ton	5,111	4,566	5,086	3,407	5,647
- Hazardous waste incinerated with energy recovery	Ton				825	606
- Hazardous waste incinerated without energy recovery	Ton				364	751
- Hazardous waste otherwise disposed	Ton				959	968
Data coverage	%	100	95	100	100	100

Note: The environmental data reported by Enaex, for the year 2024, has been externally verified by an independent third party to ensure its accuracy, traceability, and consistency with the applicable reporting standards

Link: <https://www.enaex.com/cl/content/uploads/sites/2/2023/07/Carta-de-Verificacion-Indicadores-v0-EN-2024.pdf>

Wastewater



The Sigdo Koppers Waste Management Program is designed to reduce waste and improve environmental performance through the following initiatives:

Managing water was a priority in 2024, especially in production operations that use technology to recirculate and reuse process water.

21% of the wastewater generated by our operations was recycled in the year. The effluent treatment systems were also strengthened to ensure that the water returned to the environment meets environmental standards and regulations.

Conducting waste audits to identify areas for improvement

Developing and implementing action plans to reduce the amount of waste generated

Setting measurable targets to minimize waste across operations

Investing in innovation and research to find new ways to reduce waste

Providing training to employees to encourage active participation in waste reduction

Integrating recycling programs to divert waste from landfills and promote circular practices

SUBSIDIARIES

		Enaex	Magotteaux Group	PVSA	Fepasa	SKIC Group	SKC
Recycled or reused water	m3	27,567	30,899	-	-	1,640	876
Liquid industrial waste	m3	105,398	317	-	-	-	619
Wastewater	m3	48,316	38,702	2,756	19,936	47,113	27,253

SIGDO KOPPERS GROUP GLOBALLY

		2020	2021	2022	2023	2024
Recycled or reused water	m3	36,927	122,394	95,007	170,112	60,982
Liquid industrial waste	m3	8,165,575	83,276	45,219	226,463	106,334
Wastewater	m3	99,891	126,096	115,608	212,362	184,076

INVESTMENTS AND COSTS

SUBSIDIARIES		Enaex	Magotteaux Group	PVSA	Fepasa	SKIC Group	SKC
Regulatory Compliance and Environmental Management	MUS\$	2,274	6,725	845	352	1,402	439

SIGDO KOPPERS GROUP GLOBALLY		2020	2021	2022	2023	2024
Regulatory Compliance and Environmental Management	MUS\$	9,000	10,058	10,256	10,234	12,037

ENVIRONMENTAL REGULATORY COMPLIANCE

Sigdo Koppers works conscientiously and stays true to its ongoing commitment to the environment and its care. It promotes active compliance with environmental regulations applicable to the businesses and everyone is encouraged to adopt environmental commitments voluntarily.

Below is detailed information on environmental audits and investigations of potential violations.

Sigdo Koppers have not paid any significant fines (> USD \$10,000) related to environmental or ecological issues in the past four fiscal years

SUBSIDIARIES		Enaex	Magotteaux Group	PVSA	Fepasa	SKIC Group	SKC
Audits by the Environmental Authority	N°	3	22	4	-	2	-
Investigations because of Violations	N°	-	1	-	-	-	-
Environmental Penalties	N°	-	1	-	-	-	-
Environmental Fines	USD	-	136	-	-	-	-
Coverage		100%	100%	100%	100%	100%	100%

SIGDO KOPPERS GROUP		2020	2021	2022	2023	2024
Audits by the Environmental Authority	N°	21	43	35	24	31
Investigations because of Violations	N°	7	1	1	1	1
Environmental Penalties	N°	2	0	2	1	1
Environmental Fines	USD	-	-	-	7,700	136

(*) In 2024, an environmental fine of USD 136 was imposed on Magotteaux Group (plant in Spain) for failing to provide environmental information to the authority by the deadline.

An investigation of a potential violation is also underway by the Environmental Authority regarding the Mexico plant of the Magotteaux Group, related to providing updated environmental information to the authority.

INCIDENTS

Sigdo Koppers has an environmental incident reporting system that classifies incidents in 3 levels based on the following criteria:

- Level 1 Incident:** Low impact on the environment. The incident occurs in the workplace but has no impacts on the ecosystem and requires minor corrective actions.
- Level 2 Incident:** Moderate impact on the physical or biological environment the consequences of which are quickly reversible in the ecosystem but which require the formal intervention of authorities via, for example, audits, orders, inquiries, health investigations, etc.
- Level 3 Incident:** Significant impact on the physical or biological environment that has medium-term or long-term impacts and is reported in the regional and/or national press. Environmental investigations are begun and it is likely that the environmental authority will impose penalties.

SUBSIDIARIES		Enaex	Magotteaux Group	Puerto Ventanas	Fepasa	SKIC Group	SKC
Level 1 Incident	N°	25	16	-	0	9	-
Level 2 Incident	N°	-	1	-	1	-	-
Level 3 Incident	N°	-	-	-	-	-	-
Coverage		100%	100%	100%	100%	100%	100%

SIGDO KOPPERS GROUP		2020	2021	2022	2023	2024
Level 1 Incident	N°	51	57	86	69	50
Level 2 Incident	N°	5	5	2	1	2
Level 3 Incident	N°	0	2	1	-	-

Notes

Globally, there were two Level 2 environmental incidents in the Sigdo Koppers Group in 2024, namely:

A fire at the Canada plant of Magotteaux Group.

A fuel spill on the railroad track of Fepasa.

(SASB - EM-MM-150a.9.)

On the other hand, there were no Level 3 incidents in Sigdo Koppers subsidiaries in 2024 that had a material impact.

There were no incidents related to permits or water quality standards and regulations.

(SASB - EM-MM-140a.2.)

ABOUT THIS REPORT

MATERIALITY ANALYSIS AT SIGDO KOPPERS

SIGDO KOPPERS CONDUCTS A COMPREHENSIVE MATERIALITY ANALYSIS TO ENSURE ITS SUSTAINABILITY EFFORTS REMAIN ALIGNED WITH STAKEHOLDER EXPECTATIONS AND BUSINESS PRIORITIES. THE PROCESS INCLUDES THE FOLLOWING KEY ELEMENTS:

01. Stakeholder Engagement:

External stakeholders are actively involved in identifying the most relevant ESG issues

02. Prioritization:

Material topics are prioritized using a materiality matrix or a similar structured approach

03. Integration with Risk Management:

The materiality assessment is integrated into the company's Enterprise Risk Management (ERM) process

04. Double Materiality Perspective:

The analysis considers both the impact of ESG issues on the company and the company's impact on society and the environment

05. Governance:

The final results of the materiality assessment are reviewed and approved by Senior Management

Materiality Matrix

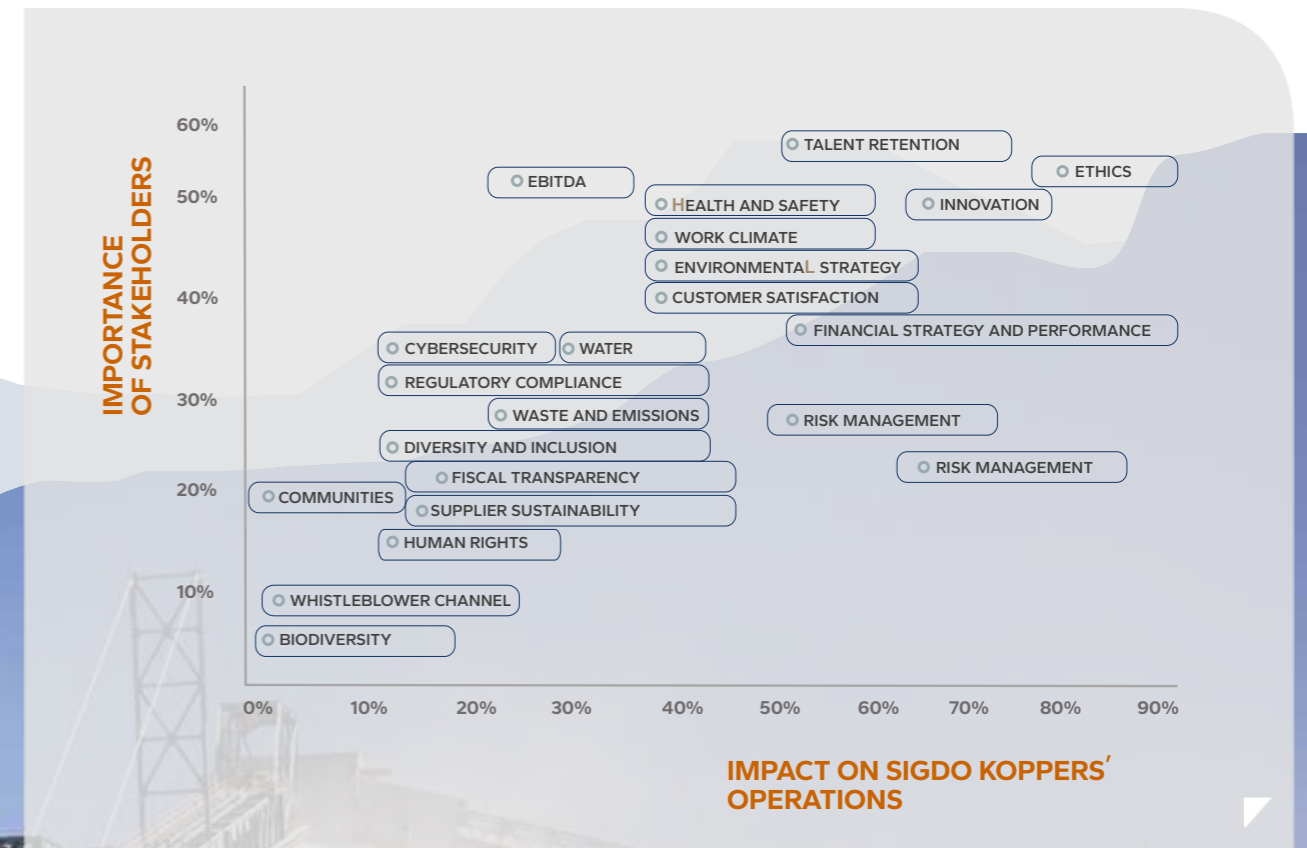

2024.

INTEGRATED REPORT

SK SIGDO KOPPERS S.A.